



**AB0602D**  
**ARCHITECTURAL BALLAST DRIVER**

Version 0.10

Date 06/25/2012

## DESCRIPTION AND FEATURES

The AB-0602D is a 6 circuit, 2400 Watts per circuit ballast driver intended for dimmable fluorescent and LED fixtures which use a switched 120VAC hot feed and a 0 - 10 VDC analog control signal to operate them. A three circuit version (AB-0302D) is also available and operates identically.

The AB-0602D can also be used as a conventional relay pack by using only the switched hot feed controls without the 0 - 10VDC analog signal.

## EXTERNAL CONTROLS

The AB-0602D can communicate with remotely located control equipment in several ways.

A USITT DMX-512 protocol bus is provided so the unit may be used with any DMX lighting console. The AB-0602D is fully patchable with respect to the DMX bus.

The AB-0602D may also be controlled by several types of wall mounted smart remote stations. Smart remotes communicate with the unit by way of a low voltage RS-485 bus. This bus is completely separate from the DMX bus. Smart remotes are used to activate preset scenes which have been stored in the AB-0602D. There are several types of smart remote stations. Multiple smart remotes of the same or different types may be chained together on the RS-485 bus. The same RS-485 bus may be chained to multiple AB-0602D units.

The AB-0602D may additionally be controlled by an arrangement of one or more momentary switches (simple remotes). The switches may be used to control a specific set of eight scenes which are stored in the AB-0602D.

## INSTALLATION

### PHYSICAL LOCATION

The unit is intended for **INDOOR USE ONLY** and should not be subjected to excessive moisture or heat. The unit should be installed where a supply of circulating air is available. The AB-0602D is designed to be wall mounted in a equipment room or electrical distribution area.

The ambient air in the installation area should be below 86 deg F.

Provide spacing between the unit and other equipment to allow air flow around the unit. See the DIMENSIONS AND LOCATIONS diagram for more information about mounting the unit.

### POWER REQUIREMENTS



The internal AB-0602D circuitry requires a 120VAC line feed. The circuitry is fused with a 1/2 Amp fast acting 1 1/4" x 1/4", 250V fast acting fuse.

### SWITCHED HOTS

A separate 120 VAC line feed is needed for each of the six switched hot loads (A - F). The maximum load for each load is 2400 Watts (20 Amps).

These connections are made on a terminal strip inside the AB-0602D. The diagram DIMENSIONS AND LOCATIONS shows the connection details.

A grounding bar is also provided.

### ANALOG (0-10VDC) OUTPUT CONNECTIONS

Connectors with screw down terminals are provided on the control circuit board for the 0 -10VDC analog output signals. Specific wiring connection point information is shown in the diagram CONTROL AND ANALOG CONNECTIONS.

### CONTROL SIGNAL CONNECTIONS

Connectors with screw down terminals are provided for connection to DMX consoles, smart remotes, and simple remote stations. Specific wiring connection point information for all external control signals is shown in the diagram CONTROL AND ANALOG CONNECTIONS.

**CONTROL AND ANALOG CONNECTIONS**

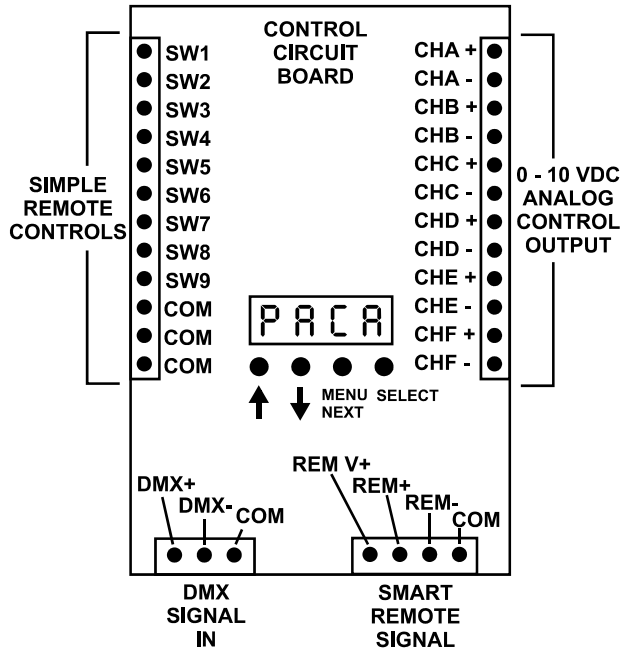

**DMX CONSOLE CONNECTIONS**

DMX console signals to the AB-0602D should be transmitted over a twisted pair, shielded, low capacitance cable. A DMX console transmits from a female, 5 Pin XLR Connector.

See the CONTROL AND ANALOG CONNECTIONS diagram for specific connection details.

**DMX TERMINATION**

A DMX bus should be terminated (only) at the last receiving device on the chain. This is done by connecting a 120 ohm, 1/4 watt resistor across the DMX DATA - and DMX DATA + lines.

**DMX CONNECTION ARRANGEMENT**

A DMX bus should be daisy chained to all its receiving units. It should NOT be connected in a star arrangement with multiple "home runs".

**CAUTION**  
REMOVE ALL POWER FROM THE AB-0602D  
BEFORE MAKING OR CHANGING DMX  
CONSOLE CONNECTIONS.

**DMX CABLE  
CONDUCTOR ARRANGEMENT FOR  
TWISTED PAIR, SHIELDED CABLE**

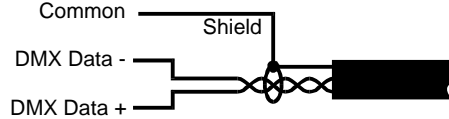

**SMART REMOTE CONNECTIONS**

There are two types of smart remotes (push button and fader) which can be used with the AB-0602D. There are multiple models of each type. They all connect to a common RS-485 bus which is controlled by a AB-0602D. Additional AB-0606D units may also be connected on the same bus. One of them will be set as the master controller by making UNIT ID ADDRESS ASSIGNMENTS.

Smart remote signals to the AB-0602D are transmitted over a two twisted pair, shielded, low capacitance cable. One pair carries the RS-485 signal and the other provides a low voltage power and common to the remotes.

A smart remote bus should be daisy chained to all its receiving units. It should NOT be connected in a star arrangement with multiple "home runs".

Each smart remote has a 4 pin connector with screw down terminals to connect to the RS-485 bus. You must get the exact wiring pinout information for the remote unit from its owners manual.

**CAUTION**  
REMOVE ALL POWER FROM THE AB-0602D  
BEFORE MAKING OR CHANGING SMART  
REMOTE CONNECTIONS.

See the CONTROL AND ANALOG CONNECTIONS diagram for specific connection details.

**SMART REMOTES CABLE CONDUCTOR  
ARRANGEMENT FOR DUAL TWISTED PAIR,  
SHIELDED CABLE**

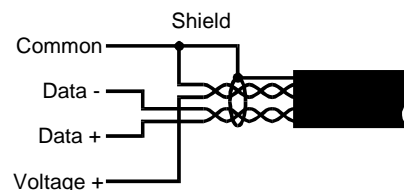

**SIMPLE REMOTE CONNECTIONS**

**CAUTION**  
REMOVE ALL POWER FROM THE AB-0602D BEFORE MAKING OR CHANGING SIMPLE REMOTE CONNECTIONS.

Scenes 1 - 8 (stored in the AB-0602D) may be used by simple remotes. A BLACKOUT function may also be accessed. A simple remote is any switch that can provide a momentary contact closure which can be applied to a specific pin on the AB-0602D simple remote controls connector.

See the CONTROL AND ANALOG CONNECTIONS diagram for specific connection details. The three COM (commons) pins are electrically tied together.

A SIMPLE REMOTE COMMON is routed to the remote switch. When the switch is operated the closure brings the common back to the applicable pin (SW1 - SW8) on the simple remote controls connector in the AB-0602D. Contact SW9 is the BLACKOUT. Almost any available low voltage wire may be used since these connections are just contact closures.

Multiple simple remotes may be used. Additionally multiple AB-0602D units may be chained to one or more simple remotes.

An example remote of switch operation using a Lightronics APP01 switch is shown below. It can activate scene 1 and invoke a blackout.

**SIMPLE REMOTE CONNECTION EXAMPLE**

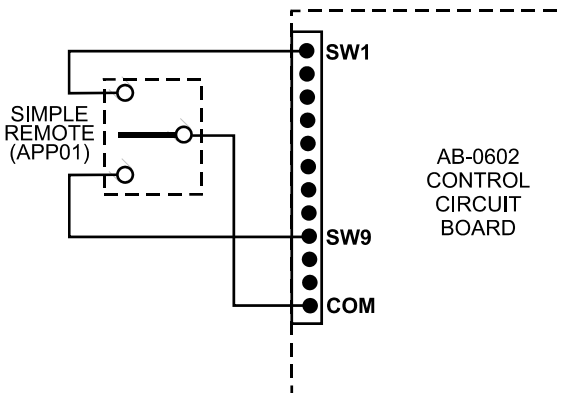

**OPERATION**

**SETUP AND OPERATING CONFIGURATION**

All operating functions and settings for the AB-0602D are menu controlled using the LED Display and the 4 buttons located below it on the control circuit board.

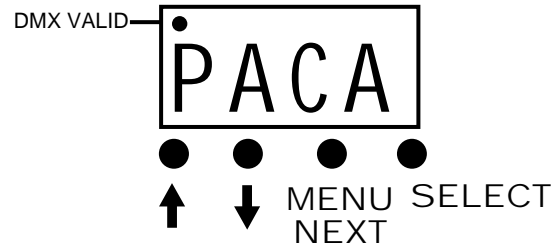

**FACTORY DEFAULT CONFIGURATION**

The AB-0602D is supplied with a factory default setup configuration. The unit may be reset to this condition by keeping the SELECT button held down while power is applied. The display briefly shows FACT while the reset is being performed. The AB-0602D is set as follows when a reset is performed:

1. The DMX pack address (PACA) will be set to DMX address 1 (POO1).
2. Softpatch is set to DMX addresses 1 - 6
3. Dropout trip points are set to 35 (14%).
4. All channels curves are set to LED1.
5. The architectural ID (ARCU) is set to OO.

**DISPLAY STATUS INDICATORS**

The LED display shows a dot near the upper left corner when a valid DMX signal is being received.

**MENU ACCESS AND USE**

Hold the MENU/NEXT button down for approx. 5 seconds to gain access to the complete menu system. If there is no button activity for 1 minute while inside the menus then the unit will revert back to the normal display (PACA).

To exit from anywhere in the menus - Hold down MENU/NEXT for approx. 5 seconds. The unit will revert back to the normal display (PACA).

A menu/display operation flow diagram is provided at the back of this manual.

**QUICK DMX ADDRESSING**

The AB-0602D has a quick DMX address setup which enables you to set the starting address of the pack (the address for channel "A") without accessing the rest of the menu system. When used, the remaining 5 channels are set to the next consecutive addresses.

During normal operation the LED display toggles back and forth between PACA and the current pack address such as P001. Use the ↑ and ↓ buttons to set different pack address. Push SELECT to save the setting when done.



If you set the pack address to P000 then the unit will run in soft patch mode. In this mode you can set ANY channel of the unit (A - F) to ANY DMX address (000-512) by using the dimmer setup (dSEt) menus. See **CHANNEL ADDRESSING** for details.

**CHANNEL TEST / LOCAL OPERATION**

You can test the operation of each dimmer channel by pushing MENU/NEXT. The display will show the intensity of channel A (00 - 99%) shown below.

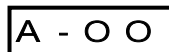

Use ↑ and ↓ to adjust the intensity to the desired level. Push MENU/NEXT to advance to the next channel (Channel B). The dimmer will return to its normal display when you go past the last channel.

The channel levels will remain when you set them. The control console can turn off the circuits by raising the channel fader to full then back down. A useful feature of the channel test mode is that the display shows the current intensity level of the channel regardless of the control signal source.

**CHANNEL ADDRESSING (SOFTPATCHING)**

In order to invoke the softpatching settings you must first set the pack address (PACA) to P000. You can set the channel DMX softpatch addresses at any time but they will be ignored if PACA is not at P000.

**TO SET CHANNEL SOFTPATCH ADDRESSES**

Push SELECT at the dSEt menu. The display will toggle between the dA-A and the current DMX address assignment number.

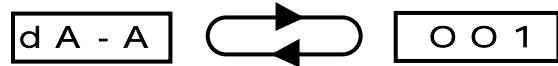

Use ↑ ↓ to set the desired DMX address (000 - 512) for the channel. Push SELECT to save the change.

Push MENU/NEXT to advance to the next channel or hold down MENU/NEXT for approx. 5 seconds to exit from the menus

**CHANNEL DROPOUT POINT**

Many fixtures cannot operate reliably at very low levels of intensity. The AB-0600D can cut off a circuit when a low level threshold is reached to prevent flickering and other undesired effects. The dropout point can be set for each of the 6 circuits.

Push SELECT at the dSEt menu. Then push MENU/NEXT until the display toggles between dd-A and the current dropout value setting. The range is from 5 to 255. 5 is the lowest.



Use ↑ and ↓ to set the desired value for that channel. Push SELECT to save the change.

Push MENU/NEXT to advance to the next channel or hold down MENU/NEXT for approx. 5 seconds to exit from the menus.

**RESPONSE CURVE SELECTION**

Each AB-0602D channel has a selection of response curves to match a variety of lamp and fixture types:

- DIM: (dinn) Used for incandescent lamps.
- LINEAR: (Linr) Used for some CFL fixtures..
- LED1: (Led1) Used for many LED fixtures.
- FLUORESCENT: (FLUO) For dimmable fluorescent ballasts

The menu used to select curves includes 4 additional items which are not currently supported. They are LED2, LED3, CUR6, and CUR7. They can be selected but will be ignored.

Push **SELECT** at the **dSEt** menu. Then push **MENU/NEXT** until the display toggles between **dC-A** and the current curve setting.

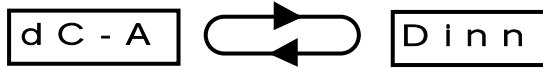

Use **↑↓** to set the desired curve for that channel. Push **SELECT** to save the change.

Push **MENU/NEXT** to move to another channel.

### WALL STATION REMOTE CONTROL

The AB-0602D can be controlled using Lightronics architectural smart remote wall stations. This is done using a NON-DMX wiring bus to connect the units. Multiple AB-0602D's and/or multiple smart remote wall stations may be connected together.

The AB-0602D can store 64 preset scenes which can be activated by the smart remotes. These scenes are grouped according to which type of smart remote can use them. Scenes 1 - 32 are reserved for push button and IR remotes. Scenes 51 - 63 are used with fader remotes. Both push button and fader remotes may be connected to the same remote bus. If multiple AB-0602D units are connected to a remote then each one will activate its own stored scene.

### BUTTON AND IR SMART REMOTES

These remotes activate individual scenes which have been stored in the AB-0602D. Scenes will activate on an "exclusive" basis (only one scene may be on at a time). Currently available button remotes are the AC-xx, AK-xx, and AI-1001.

These units are set to control scenes starting at scene number one. It is possible to order a remote to use other scenes.

The scene activation buttons will toggle. In other words a scene will go OFF if you push its button while the scene is active.

The OFF button invokes a system wide BLACKOUT. (all scenes will be turned off regardless of their source).

### FADER SMART REMOTES

These units use specific individual scenes which have been stored in the AB-0602D on a "pile on" basis. In other words multiple scenes will merge together in a "greatest of " fashion. This means that the intensity of any given channel will go to the highest level of all the scenes which use it. Currently available fader remotes are the AF-2104, AF-3107 and AF-5113.

All fader remotes will interact with scenes beginning at scene 51. This refers to the lowest numbered fader on the remote. The other faders on that remote will use the next consecutively numbered scenes (52, 53, 54, etc.).

### UNIT ID ADDRESS ASSIGNMENT

The smart remote connection bus used with AB-0602D's must have a single controlling (master) unit on it. Assigning the master unit on the bus is accomplished by setting unit ID addresses.

When using only one AB-0602D with smart remotes control, the unit must be set to UNIT ADDRESS 00. If multiple AB-0602D's are used then one of them (and ONLY one of them) must be set to UNIT ADDRESS 00. The remaining units may be set to any other unit address. It is recommended that they be set to consecutive numbers starting at 01.

### TO SET THE UNIT ID ADDRESS

Hold **MENU/NEXT** for approx. 5 seconds to access the menus. The display will show **dSEt**.

Push **MENU/NEXT** until the display shows **SYSt**.

Push **SELECT**.

Push **MENU/NEXT** until the display toggles between **ArcU** and the current unit address.

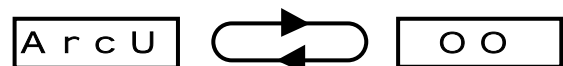

Use **↑** and **↓** to change the unit address number. Then push **SELECT** to save the selection.

Hold **MENU/NEXT** for approx. 5 seconds to exit from the menus.

**CREATING AND SAVING SCENES**

Scenes to be activated by an AB-0602D must first be created and stored (recorded) in the unit. Scene recording stores the current intensity levels of all six channels in the unit regardless of how they were set.

Intensity levels for a scene can be set using only the dimmer or by operating the unit with a DMX console. Each scene created has an associated user settable fade time.

A universal BLACKOUT scene (all channels OFF) is also available. It appears as scene number 00 in the menus. The blackout scene has a user settable fade time.

**TO RECORD A SCENE**

Set the intensity for each channel in the unit to the desired brightness.

Hold MENU/NEXT for aprox. 5 seconds to access the menus. The display will show dSET.

Push MENU/NEXT until the display shows SYS t. Push SELECT. The display will toggle between CnFG and the currently selected control source.

Push MENU/NEXT until the display toggles between **ScEn** and the **00** (scene 00).

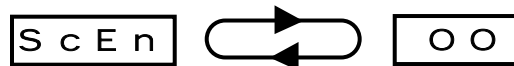

Use ↑ and ↓ to change the scene number. Then push SELECT to record the intensity levels.

The menu will advance to allow you to set the fade time for that scene. The display will toggle between **FAdE** and the current fade time (seconds).



Use ↑ and ↓ to change the time. Then push SELECT to save the setting.

The display will revert to the scene number selection menu. If you are operating with a DMX console you can change the channel levels and record to another scene. If operating in local mode you will have to exit from the menus to set new channel intensities.

Hold MENU/NEXT for aprox. 5 seconds to exit from the menus.

**MAINTENANCE AND REPAIR**



**FUSE REPLACEMENT**

**REMOVE ALL POWER TO THE UNIT BEFORE REPLACING THE FUSE**

The only user serviceable part is a 1 1/4" X 1/4" fuse. Replace the fuse ONLY with a 1/2 Amp, 250VAC, fast blow fuse. The diagram DIMENSIONS AND LOCATIONS shows the fuse location.

**INTERNAL SERVICE**

Internal service on the unit by other than Lightronics authorized agents will void the warranty.

If service is required, contact the dealer from whom you purchased the dimmer, or Lightronics Service Department, 509 Central Drive, Virginia Beach, VA 23454. Tel: 757 486 3588.

MENU / DISPLAY OPERATION

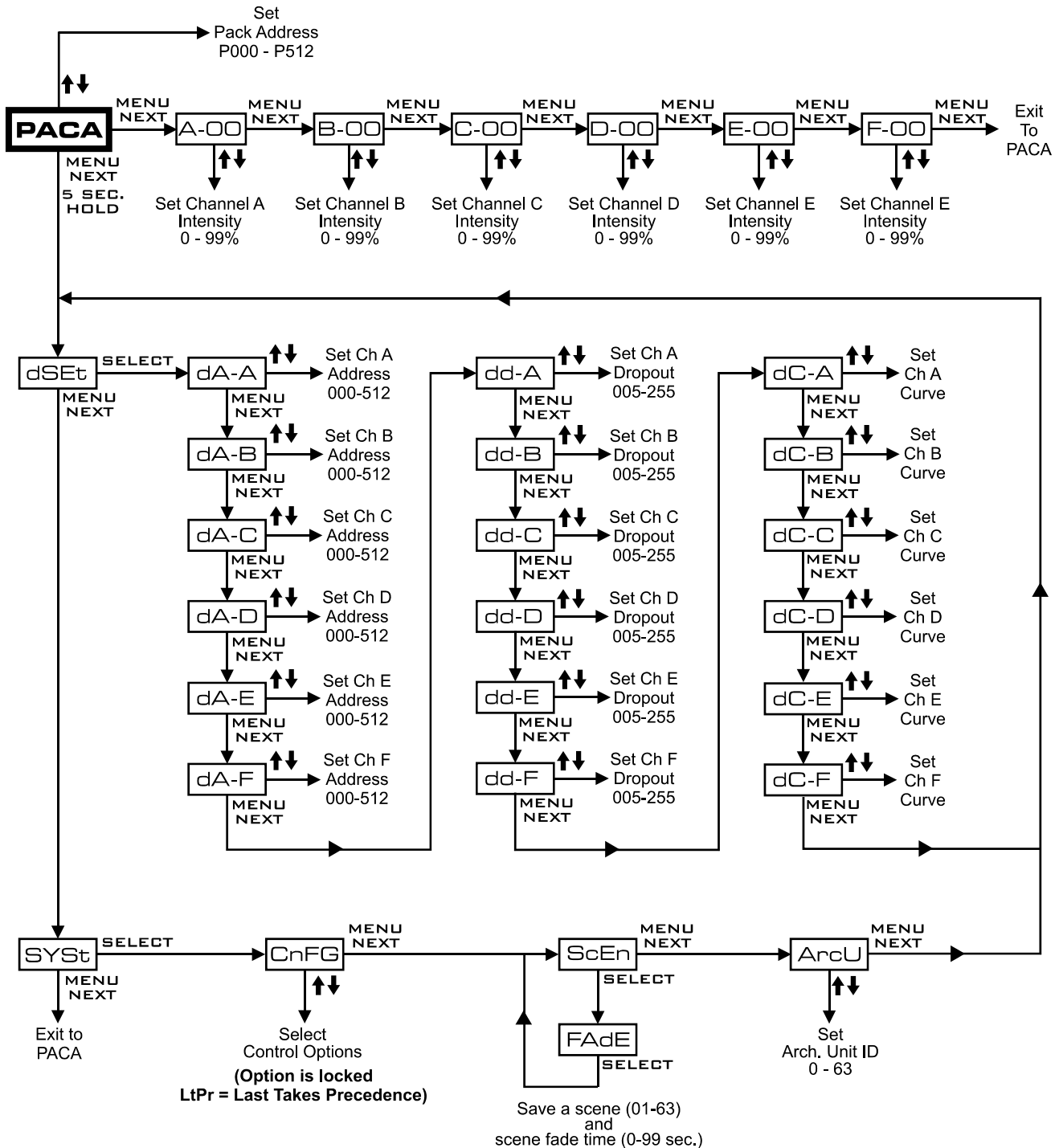



**DIMENSIONS AND LOCATIONS**

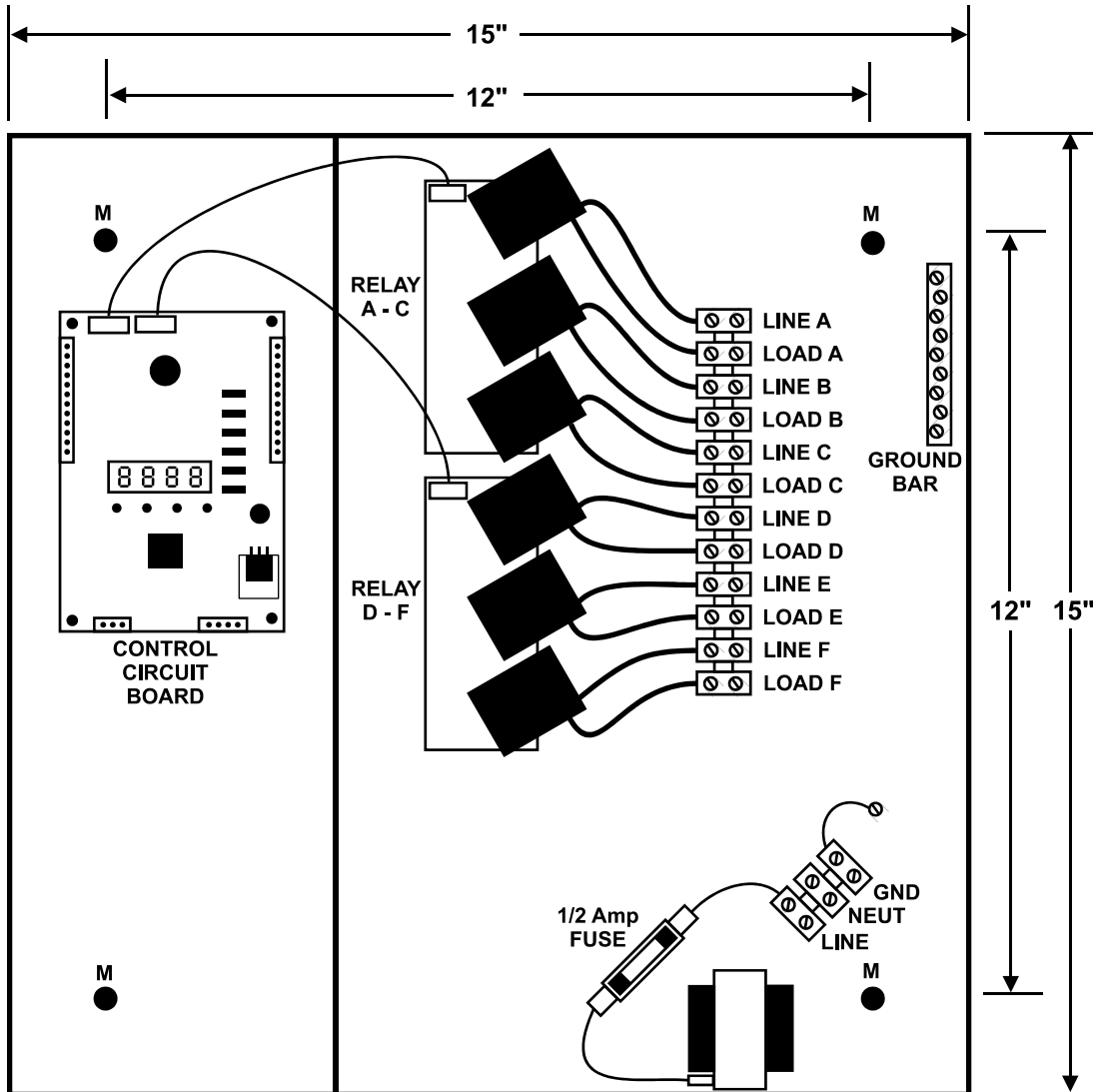

Chassis depth is 3.25".

M = Mounting Holes: 0.255" DIAM. Will accept a 1/4 - 20 bolt.

Four dual knockouts are provided on each side and on the top and bottom.

A graphic banner for the warranty. It features two dark grey, ribbon-like shapes pointing outwards from a central dark grey rectangle. The word "LIGHTRONICS" is written in white, sans-serif capital letters on each of the ribbon shapes. The word "WARRANTY" is written in large, white, sans-serif capital letters on the central dark grey rectangle.

LIGHTRONICS **WARRANTY** LIGHTRONICS

All Lightronics products are warranted for a period of TWO/FIVE YEARS from the date of purchase against defects in materials and workmanship.

---

This warranty is subject to the following restrictions and conditions:

- A) If service is required, you may be asked to provide proof of purchase from an authorized Lightronics dealer.
- B) The FIVE YEAR WARRANTY is only valid if the warranty card is returned to Lightronics accompanied with a copy of the original receipt of purchase within 30 DAYS of the purchase date, if not then the TWO YEAR WARRANTY applies. Warranty is valid only for the original purchaser of the unit.
- C) This warranty does not apply to damage resulting from abuse, misuse, accidents, shipping, and repairs or modifications by anyone other than an authorized Lightronics service representative.
- D) This warranty is void if the serial number is removed, altered or defaced.
- E) This warranty does not cover loss or damage, direct or indirect arising from the use or inability to use this product.
- F) Lightronics reserves the right to make any changes, modifications, or updates as deemed appropriate by Lightronics to products returned for service. Such changes may be made without prior notification to the user and without incurring any responsibility or liability for modifications or changes to equipment previously supplied. Lightronics is not responsible for supplying new equipment in accordance with any earlier specifications.
- G) This warranty is the only warranty either expressed, implied, or statutory, upon which the equipment is purchased. No representatives, dealers or any of their agents are authorized to make any warranties, guarantees, or representations other than expressly stated herein.
- H) This warranty does not cover the cost of shipping products to or from Lightronics for service.
- I) Lightronics Inc. reserves the right to make changes as deemed necessary to this warranty without prior notification.