

The AC-2016 is a wall mounted, sixteen scene, digital remote for use with the Lightronics AR-1202 architectural dimmer. User operation is as simple as it can get (16 numbered scene buttons and an "OFF" control). LED scene indicators always display the active scene number.

The unit fits into a standard double gang wall switch box. The unit communicates with the AR-1202 via a 4 wire bus which will accommodate multiple AC-2016 units and other remote units. All AC-2016 wiring is low voltage.

The unit operates in an exclusive mode where one scene may be activated at a time. When a scene is selected, the AR-1202 fades at a user controlled rate to that scene. A blackout button is also provided to shut off all scenes. Scenes activated by the AC-2016 are actually set up and stored in the AR-1202 dimmer. The AC-2016 only tells the AR-1202 which scene to activate. The AR-1202 dimmer can be programmed to respond to the AC-2016 in various ways to create zone controls.



**INSTALLATION**

The AC-2016 connects to the AR-1202 via a shielded, 4 conductor, low capacitance data cable arranged as 2 twisted pairs. One pair connects to the DATA - and DATA + signals. The other pair carries the common and power.

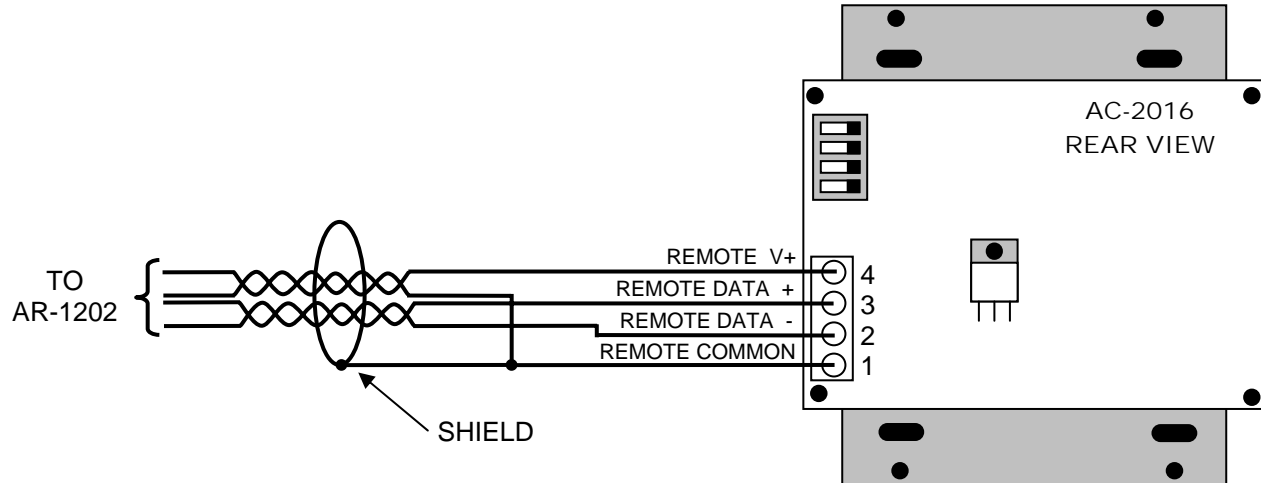

**CONNECTIONS**

**SINGLE UNIT:** Connect the 4 cable wires to the screw down terminals on the back of the unit. Connect the cable shield to the REMOTE COMMON pin. The other end of the cable connects to a small terminal strip inside the AR-1202 dimmer. See the AR-1202 Owners Manual for additional wiring details.

**MULTIPLE UNITS:** Follow the instructions for a single unit for the first AC-2016. Connect pin 1 of the second unit to pin 1 of the first unit. Continue matching pin numbers for the remaining wires and shield. Repeat the procedure for additional AC-2016 units.

OPERATION

GENERAL OPERATION

No setup or turn on procedure is needed. When the AR-1202 dimmer is powered on, the AC-2016(s) will also be powered. If communication with the AR-1202 cannot be established, an AC-2016 will appear to be repeatedly scanning through all scenes.

Scenes to be activated by an AC-2016 must have already been created and stored in the AR-1202. See the AR-1202 Owners Manual for instruction on programming scenes.

If a scene is activated from an "OFF" condition but has no channels assigned to it which are on or partially on then the scene LED indicator will light and the "OFF" indicator will remain ON.

If a scene which has no channels on or partially on is activated while another scene which does have on or partially on channels is active then the LED indicator for the scene will light and the previous scene indicator will remain ON.

ACCESSING SCENE BLOCKS WITH ONE OR MORE AC-2016 UNITS

The AC-2016 can be set to activate a specific block of 16 scenes which have been created and stored in the AR-1202. This is done using the DIP switches on the rear of the AC-2016. If multiple AC-2016's are used, they may be set independently to activate the same or different scene blocks. In all cases, the "OFF" button will turn off ALL scenes.

The table and drawing below shows the switch positions for selecting scene blocks.

SCENE BLOCK SWITCH SETTINGS

Switch #	Scenes 1-16	Scenes 9-24	Scenes 17-32	Scenes 25-40	Scenes 33-48	Scenes 41-56
4	➡	➡	➡	➡	➡	➡
3	➡	➡	➡	➡	➡	➡
2	➡	➡	➡	➡	➡	➡
1	➡	➡	➡	➡	➡	➡

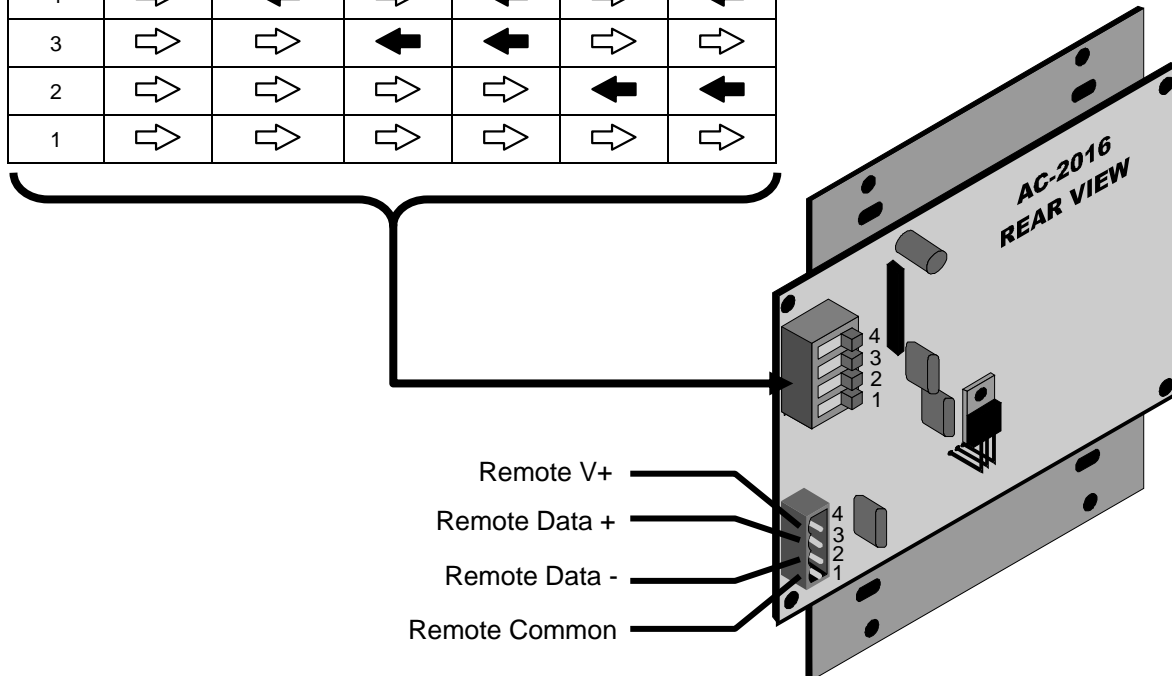

## MAINTENANCE AND REPAIR

## TROUBLESHOOTING

Check the cable and its connections

If the unit is being used with a AR-1202 system - ensure that one (and only one) of the AR-1202 dimmer(s) in the system is set to UNIT ADDRESS 00

Make sure that the DIP switches are set to the desired scene block.

## OWNER MAINTENANCE

There are no user serviceable parts in the unit. Service by other than Lightronics authorized agents will void your warranty.

## OPERATING AND MAINTENANCE ASSISTANCE

Dealer and Lightronics Factory personnel can help you with operation or maintenance problems. Please read the applicable parts of this manual before calling for assistance.

If service is required - contact the dealer from whom you purchased the unit or contact Lightronics, Service Dept., 509 Central Drive, Virginia Beach, VA 23454 TEL: (757) 486-3588.



LIGHTRONICS INC. **WARRANTY** LIGHTRONICS INC.

All Lightronics products are warranted for a period of TWO/FIVE YEARS from the date of purchase against defects in materials and workmanship.

---

This warranty is subject to the following restrictions and conditions:

- A) If service is required, you may be asked to provide proof of purchase from an authorized Lightronics dealer.
- B) The FIVE YEAR WARRANTY is only valid if the warranty card is returned to Lightronics accompanied with a copy of the original receipt of purchase within 30 DAYS of the purchase date, if not then the TWO YEAR WARRANTY applies. Warranty is valid only for the original purchaser of the unit.
- C) This warranty does not apply to damage resulting from abuse, misuse, accidents, shipping, and repairs or modifications by anyone other than an authorized Lightronics service representative.
- D) This warranty is void if the serial number is removed, altered or defaced.
- E) This warranty does not cover loss or damage, direct or indirect arising from the use or inability to use this product.
- F) Lightronics reserves the right to make any changes, modifications, or updates as deemed appropriate by Lightronics to products returned for service. Such changes may be made without prior notification to the user and without incurring any responsibility or liability for modifications or changes to equipment previously supplied. Lightronics is not responsible for supplying new equipment in accordance with any earlier specifications.
- G) This warranty is the only warranty either expressed, implied, or statutory, upon which the equipment is purchased. No representatives, dealers or any of their agents are authorized to make any warranties, guarantees, or representations other than expressly stated herein.
- H) This warranty does not cover the cost of shipping products to or from Lightronics for service.
- I) Lightronics Inc. reserves the right to make changes as deemed necessary to this warranty without prior notification.