

PRODUCT DESCRIPTION

The MX-32 is a 32 channel 0 - 10 volt analog signal multiplexer that transmits a multiplexed control signal compatible with Lightronics (LMX) and similar three pin multiplex protocols. The MX-32 is provided as an in-line unit in a very compact housing. The unit receives DC voltage analog channel signals via a small (DB37) connector and transmits the multiplex signal via a 3 pin XLR connector. The unit is powered by the dimmer chain to which it is connected.

The unit can be supplied to accommodate 0 - 15 volt and 0 - 20 volt analog input signals. In certain cases it may be possible to install a version of this unit into an existing lighting control console. There are space and warranty considerations. This modification is supplied only as Lightronics factory retrofit. Contact your dealer for additional information.



Front View

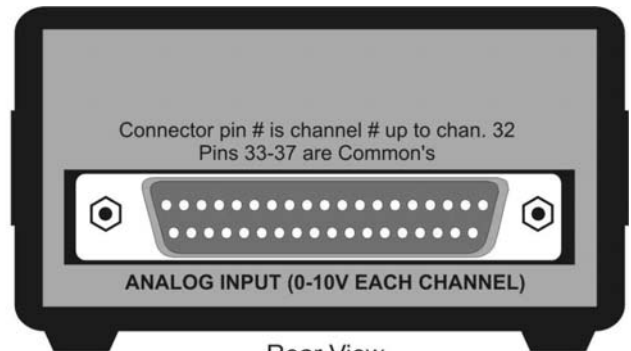

Rear View

Connections: The unit will be powered from the dimmer chain on pin 2 of the female 3 pin XLR connector. The multiplex signal is on pin # 3. Pin # 1 is the common (signal ground)

Connect the input control lines to the DB-37 connector (pin # = channel # ) (up to 32 channels). Pins 33 thru 37 are available for input signal grounds.

Signal Input Connector  
Pin Locations

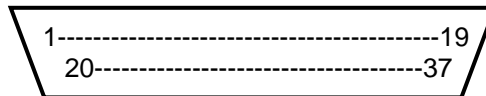

OPERATION

There are no settings or controls . The unit translates automatically as long as it is connected, the power is supplied to the XLR connector, and analog input signals are supplied.

MAINTENANCE

There are no user servicable parts in the unit. Service by other than Lightronics authorized agents will void the warranty. If service is required, contact the dealer from whom you purchased the unit or contact Lightronics.



All Lightronics products are warranted for a period of TWO/FIVE YEARS from the date of purchase against defects in materials and workmanship.

---

This warranty is subject to the following restrictions and conditions:

- A) If service is required, you may be asked to provide proof of purchase from an authorized Lightronics dealer.
- B) The FIVE YEAR WARRANTY is only valid if the warranty card is returned to Lightronics accompanied with a copy of the original receipt of purchase within 30 DAYS of the purchase date, if not then the TWO YEAR WARRANTY applies. Warranty is valid only for the original purchaser of the unit.
- C) This warranty does not apply to damage resulting from abuse, misuse, accidents, shipping, and repairs or modifications by anyone other than an authorized Lightronics service representative.
- D) This warranty is void if the serial number is removed, altered or defaced.
- E) This warranty does not cover loss or damage, direct or indirect arising from the use or inability to use this product.
- F) Lightronics reserves the right to make any changes, modifications, or updates as deemed appropriate by Lightronics to products returned for service. Such changes may be made without prior notification to the user and without incurring any responsibility or liability for modifications or changes to equipment previously supplied. Lightronics is not responsible for supplying new equipment in accordance with any earlier specifications.
- G) This warranty is the only warranty either expressed, implied, or statutory, upon which the equipment is purchased. No representatives, dealers or any of their agents are authorized to make any warranties, guarantees, or representations other than expressly stated herein.
- H) This warranty does not cover the cost of shipping products to or from Lightronics for service.
- I) Lightronics Inc. reserves the right to make changes as deemed necessary to this warranty without prior notification.