



# RA - 122

## RACK MOUNT ARCHITECTURAL DIMMER

### OWNERS MANUAL



**Version 0.93**  
**09/26/2011**

**RA – 122 RACK MOUNT ARCHITECTURAL DIMMER**

**TABLE OF CONTENTS**

RA-122 UNIT DESCRIPTION	3	Setting the Internal Clock	14
EXTERNAL CONTROLS	3	Setting the Date	14
REAL TIME CLOCK EVENT SYSTEM	3	Setting the Time of Day	14
POWER REQUIREMENTS	3	Setting the Day of the Week	14
INSTALLATION	3	Programming Events	15
Physical Location	3	Selecting an Event	16
Power Input Connections	3	Assigning a Scene and Scene Action	16
Three Phase Power Connections	4	Choosing Day or Date Based Events	16
Single Phase Power Connections	5	Setting Date Based Triggers	16
Load Connections	6	Setting Day Based Triggers	16
Control Signals Connections	6	MAINTENANCE AND REPAIR	18
Control Signals Connector (DB25)	6	Troubleshooting	18
DMX Console Connections	6	Owner Maintenance	18
DMX Termination	7	Operating and Maintenance Assistance	18
Smart Remote Connections	7	RA-122 UNIT SPECIFICATIONS	18
Simple Remotes Connections	8	WARRANTY	19
RA-122 Unit Setup	8		
Using The Menu System	9		
System Mode	9		
System Power Setup	9		
Unit Address Assignment	9		
Dimmer Channel Setup	10		
Channel Limiting	10		
Channel NON-DIM (Relay) Mode	10		
DMX I/O Setup	10		
Dimmer Channel Assignment	10		
Console Lockout	11		
Remote Lockout	11		
Creating and Editing Scenes	11		
To Create a Scene Manually	11		
To Copy a Scene	12		
To Record a Live Scene	12		
Scene Fade Time	12		
Scene Blackout Fade Time	12		
OPERATION	12		
Over Temperature Condition	12		
Cooling Fan	12		
Manual Operation	12		
DMX Console Operation	13		
Smart Remotes Operation	13		
Button and IR Smart Remotes Operation	13		
Fader Smart Remotes Operation	13		
Simple Remotes Operation	13		
EVENT SYSTEM OPERATION	14		
Event System Enable	14		
To Control Event Triggering	14		

**RA – 122 RACK MOUNT ARCHITECTURAL DIMMER**

Revision 0.93

**OWNERS MANUAL**

09/26/2011

**RA-122 UNIT DESCRIPTION**

The RA-122 consists of a processor and 12 dimmer channels of 2.4KW each. Each dimmer channel is protected by a 20 Amp circuit breaker. Heavy duty filtering chokes are used to reduce noise. Dimmer channel semiconductors exceed a 200% load carrying capacity overhead allowance. The RA-122 may be controlled by DMX controllers and several types of wall remote stations. Dimensions and weight information is given at the end of this manual.

**EXTERNAL CONTROLS**

The unit can communicate with remotely located control equipment in several ways.

A USITT DMX-512 protocol bus is provided so the unit may be used with any DMX lighting console. The RA-122 is fully patchable with respect to the DMX bus.

The RA-122 may also be controlled by several types of wall mounted smart remote stations. Smart remotes communicate with the RA-122 by way of a low voltage RS-485 bus. This bus is completely separate from the DMX bus. Smart remotes are used to activate scenes which have been prestored in the RA-122. There are several types of smart remote stations. Multiple smart remotes of the same or different types may be chained together on the RS-485 bus. The same RS-485 bus may be chained to multiple RA-122 dimmer packs.

The RA-122 may additionally be controlled by an arrangement of one or more momentary switches (simple remotes). The switches may be used to control a specific set of scenes prestored in the RA-122.

**REAL TIME CLOCK EVENT SYSTEM**

The RA-122 contains an internal clock and timer subsystem. This subsystem may be used to create events which activate and switch between preset lighting scenes based upon times, days, and dates. A total of 128 events may be programmed.

**POWER REQUIREMENTS**

The RA-122 may be operated from 50/60 Hz, 120/208 VAC, three phase power or from 50/60 Hz, 120/240 VAC, single phase power. Input power to the unit must be capable of delivering 80 Amps per line if using three phase or 120 Amps per line if using single phase power.

The RA-122 can operate using only 2 phases of a 3 phase power service. This is NOT recommended since it causes an unbalanced load to the power feed source.

**INSTALLATION****PHYSICAL LOCATION**

The unit is intended for INDOOR OPERATION ONLY and should not be subjected to excessive moisture or heat. The unit should be installed where a supply of circulating air is available. The RA-122 is designed to be installed in a standard 19 inch equipment rack. Support be provided at the rear of the unit if it is installed in a rack.

The RA-122 is fan cooled. Air is drawn in from the vent slots at each side and exits the unit from the bottom of the front panel. Be sure that these areas are not restricted.

**POWER INPUT CONNECTIONS**

 **WARNING**   
**MAKE CERTAIN POWER IS REMOVED  
FROM THE FEED CIRCUITS  
BEFORE YOU BEGIN INSTALLATION.**

Consult applicable electrical codes to determine the proper wire type and methods.

The RA-122 operates using either three phase 120/208 VAC or single phase 120/240 VAC power. The unit is shipped from the factory as a THREE PHASE unit. It can be field converted to a single phase unit.

**RA – 122 RACK MOUNT ARCHITECTURAL DIMMER**

Revision 0.93

**OWNERS MANUAL**

09/26/2011

## THREE PHASE POWER CONNECTIONS

 **WARNING**   
**MAKE CERTAIN POWER IS REMOVED  
 FROM THE FEED CIRCUITS  
 BEFORE YOU BEGIN INSTALLATION.**

## REQUIREMENTS

True 120/208VAC three phase power must be supplied to operate the RA-122 in the 3 phase configuration. This means that the voltage across any two lines must be 208 VAC. All three phases must be supplied. The feed circuit must be able to supply 80 Amps for each hot line.

**THE UNIT WILL NOT OPERATE IN IT'S THREE PHASE CONFIGURATION USING ONLY 2 LINES OF A 3 PHASE 120/208 VAC SUPPLY CIRCUIT.**

## CONNECTIONS

Connect the 3 in hot feed lines to the 3 terminals on the input power terminal block (H1, H2, H3).

Connect the feed neutral to the NEUTRAL bus bar.

Connect the feed ground to the GROUND lug.

See the section SYSTEM POWER SETUP for operation using 3 phase connections.

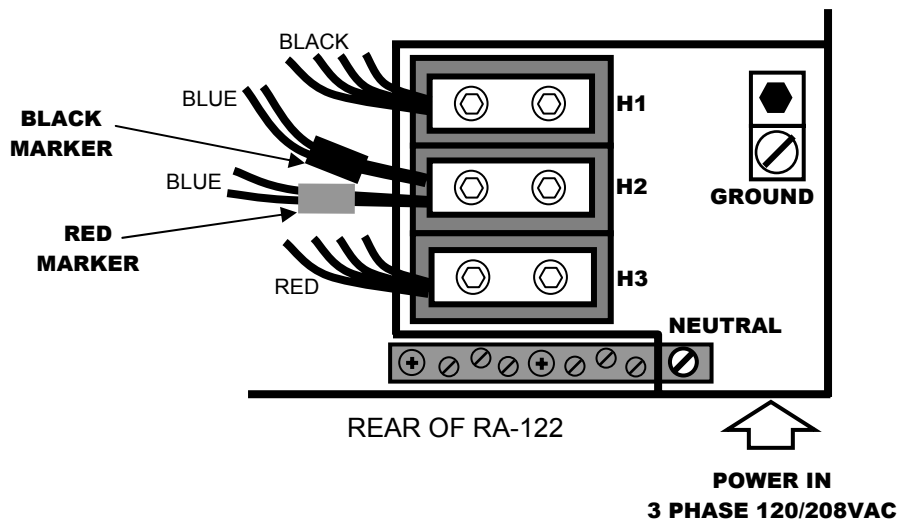
**THREE PHASE POWER CONNECTIONS**

**RA – 122 RACK MOUNT ARCHITECTURAL DIMMER**

Revision 0.93

**OWNERS MANUAL**

09/26/2011

## SINGLE PHASE POWER CONNECTIONS

**WARNING**
  
**MAKE CERTAIN POWER IS REMOVED  
FROM THE FEED CIRCUITS  
BEFORE YOU BEGIN INSTALLATION.**

## REQUIREMENTS

The RA-122 can operate as a single phase unit using only 2 phases of a 3 phase power source. This is **NOT RECOMMENDED** since it causes an unbalanced load to the power source.

The unit should be connected to two hot lines which are **NOT** the same phase.

The feed circuit must be able to supply 120 Amps for each line.

## CONNECTIONS

There are three terminals on the input terminal power block (H1, H2, H3). When operating the RA-122 on single phase power, the center (H2) terminal is not used. The wires connected to the left side of the H2 terminal contain color coded sleeves (RED and BLACK). These wires must be moved and distributed to the H1 and H2 terminals. Remove the wires from the H2 terminal and connect them to H1 and H2 such that the sleeve color matches the wire colors on H1 and H2.

Connect the feed neutral to the NEUTRAL bus bar.

Connect the feed ground to the GROUND lug.

See the section SYSTEM POWER SETUP for operation using single phase connections.

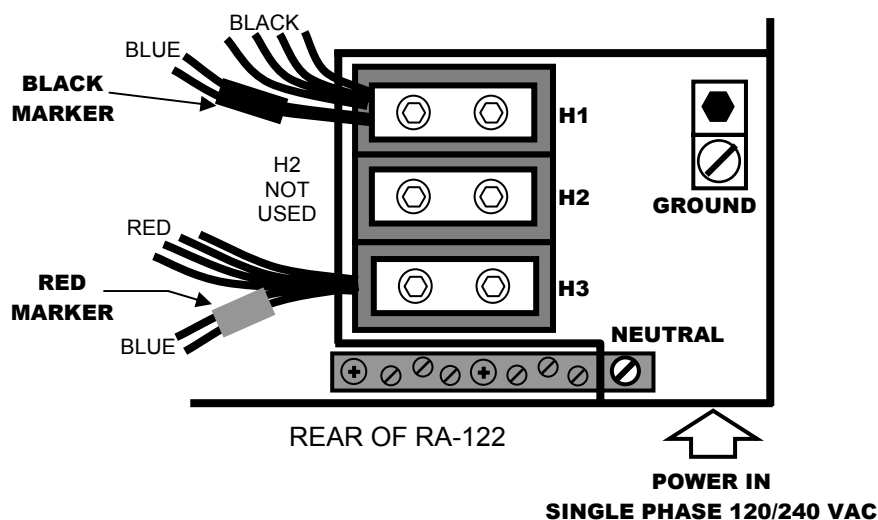
**SINGLE PHASE POWER CONNECTIONS**

**RA – 122 RACK MOUNT ARCHITECTURAL DIMMER**

Revision 0.93

**OWNERS MANUAL**

09/26/2011

**LOAD CONNECTIONS**

The RA-122 is supplied with one of several different rear load connection panels. In all cases the lowest number dimmer channel output connection is on the left when the unit is viewed from the rear panel.

**CONTROL SIGNALS CONNECTIONS**

Two male DB25 connectors are provided at the rear of the RA-122 to accommodate all external control signals. Specific pins on the DB25 connector are used to connect each different type of control device. Control devices include a DMX console, multi-scene remotes, and simple remote stations.

One of the connectors is used for control signal input, the other is to pass the control signals to another RA-122. The connectors are "hardwired" together so either one can be used for "in" or "out".

The RA-122 is supplied with a ribbon cable which can be used to chain multiple RA-122 dimmers together in a rack.

A cable mount, female, DB25 connector is also provided to accommodate all external control signals.

Wiring pin-out for the DB25 connectors is shown below.

**CONTROL SIGNALS CONNECTOR (DB25)**

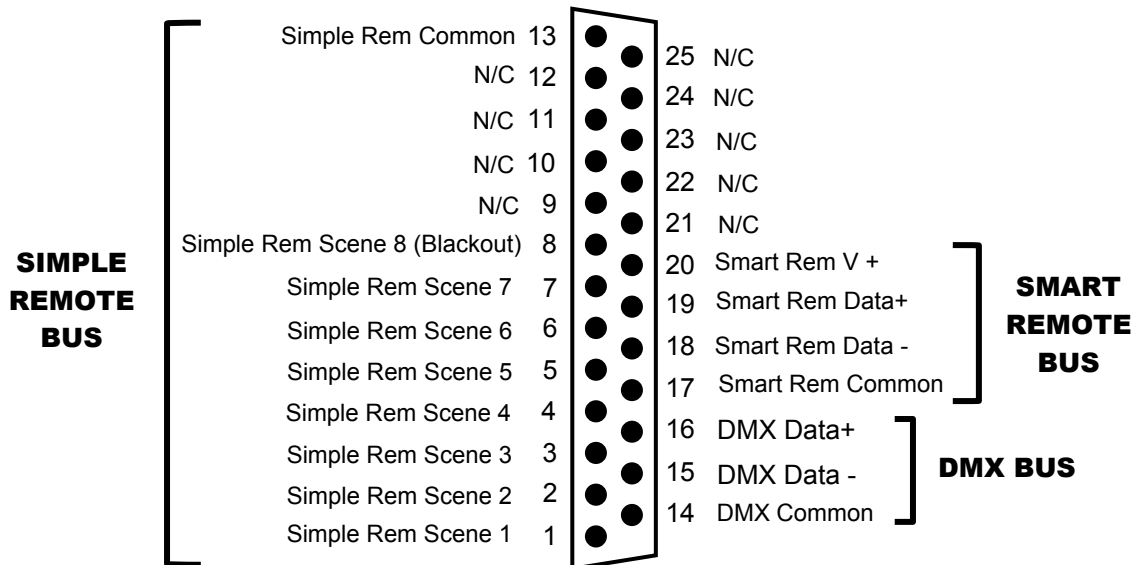

**DMX CONSOLE CONNECTIONS**

DMX console signals to the RA-122 should be transmitted over a twisted pair, shielded, low capacitance cable. Wiring data for DMX cabling is shown below. A DMX console transmits from a female, 5 Pin XLR Connector.

DMX CABLE CONDUCTOR ARRANGEMENT FOR TWISTED PAIR, SHIELDED CABLE

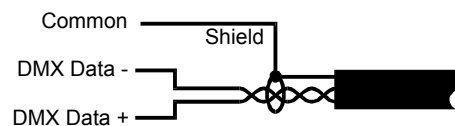

**DMX XLR CONNECTOR SIGNALS**

PIN #	FUNCTION
1	DMX COMMON
2	DMX DATA -
3	DMX DATA +
4	NOT USED
5	NOT USED

5 PIN FEMALE XLR CONNECTOR

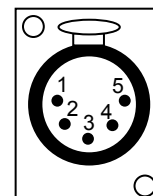

**RA – 122 RACK MOUNT ARCHITECTURAL DIMMER**

Revision 0.93

**OWNERS MANUAL**

09/26/2011

**DMX TERMINATION**

A DMX bus should be terminated (only) at the last receiving device on the chain. This is done by connecting a 120 ohm, 1/4 watt resistor across the DMX DATA - and DMX DATA + lines.

A DMX bus should be daisy chained to all its receiving units. It should NOT be connected in a star arrangement with multiple "home runs".

**SMART REMOTE CONNECTIONS**

**CAUTION**  
 REMOVE ALL POWER FROM THE RA-122  
 BEFORE MAKING OR CHANGING SMART  
 REMOTE CONNECTIONS.

There are two types of smart remotes (push button and fader) which can be used with the RA-122. There are multiple models of each type. They all connect to a common RS-485 bus which is controlled by a RA-122. Additional RA-122 dimmers may also be connected on the same bus. One of them will be set as a master bus controller by the UNIT ADDRESS ASSIGNMENT.

Smart remote signals to the RA-122 are transmitted over a two twisted pair, shielded, low capacitance cable. One pair carries the RS-485 signal and the other provides a low voltage power and common to the remotes.

A smart remote bus should be daisy chained to all its receiving units. It should NOT be connected in a star arrangement with multiple "home runs".

Each smart remote has a 4 pin connector with screw down terminals to connect to the RS-485 bus. You must get the exact wiring pinout information for the remote unit from its owners manual. The connection at the RA-122 end is made through the rear panel DB25 connector. Refer to the CONTROL SIGNAL CONNECTIONS section in this manual for exact pinout information.

An example of smart remote connections is shown below.

**SMART REMOTES CABLE ARRANGEMENT**

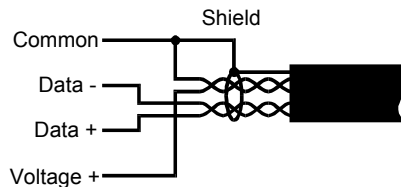

**SMART REMOTES CONNECTIONS EXAMPLE**

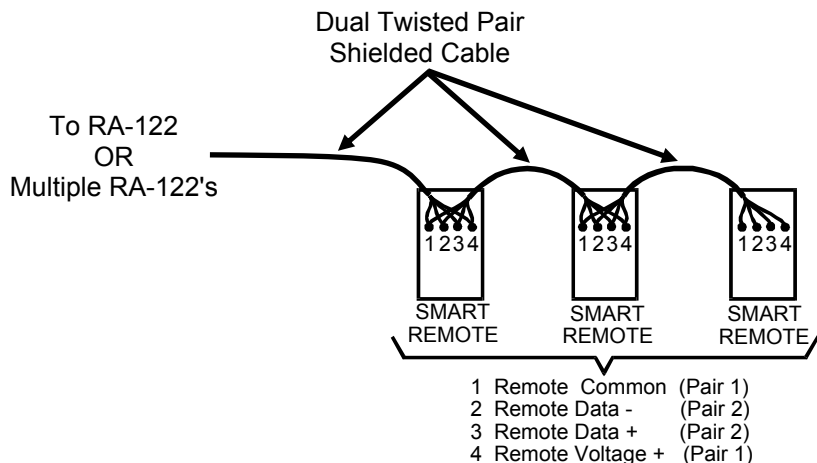

**SIMPLE REMOTES CONNECTIONS**

**CAUTION**  
 REMOVE ALL POWER FROM THE RA-122  
 BEFORE MAKING OR CHANGING SIMPLE  
 REMOTE CONNECTIONS.

Since these are contact closures almost any available low voltage wire may be used.

An example of a simple remote connection using a Lightronics APP01 is shown below.

Scenes 1 - 7 (stored in the RA-122) may be accessed by simple remotes. A BLACKOUT FUNCTION may also be accessed. A simple remote is any switch which can provide a momentary contact closure that can be applied to a specific pin on the RA-122 CONTROL SIGNALS CONNECTOR (DB25 connector).

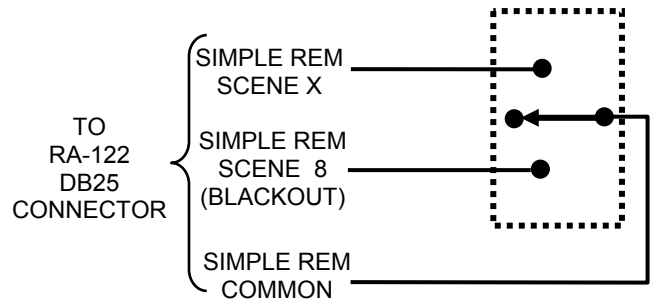

The SIMPLE REMOTE COMMON is routed to the remote. When the remote is operated the closure brings the signal back to the applicable simple scene number connection point at the RA-122 CONTROL SIGNALS CONNECTOR (DB25 connector).

**RA-122 UNIT SETUP**

**FRONT PANEL (PARTIAL VIEW)**

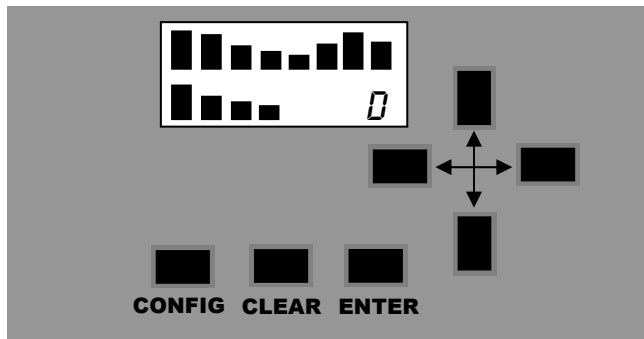

The RA-122 must be set up (configured) as part of the installation process in any application. This set up process is done from the front panel of the unit using five menus which are described below.

**SYSTEM SETUP** should be done first. It includes: setting the System Mode, System ID, and System Power Setup.

**DIMMER SETUP** should be done next. It includes Channel Limiting and Dim/Non-Dim selection.

**DMX I/O SETUP** must be performed if the unit will be used with a DMX console. This setup assigns (patches) dimmer channels to DMX channels and can lockout the wall remote stations.

**SCENE SETUP** must be performed to create scene presets to be activated from the remote control stations or by the clock/timer subsystem.

**EVENT SETUP** must be done if the clock/timer subsystem will be used. It includes Setting the Clock and Programming Events.



**RA – 122 RACK MOUNT ARCHITECTURAL DIMMER**

**TOP LEVEL MENUS LAYOUT**

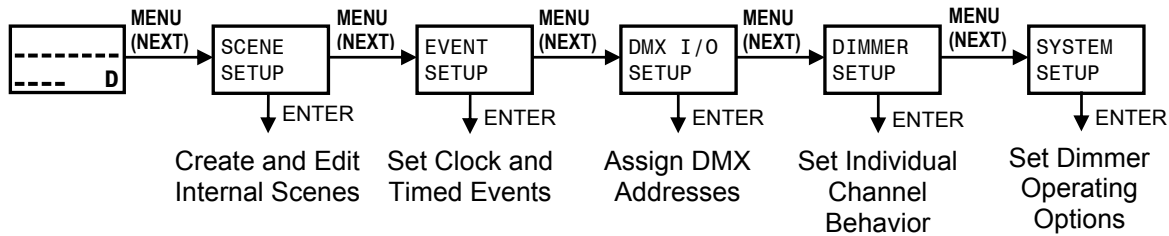

**USING THE MENU SYSTEM**

The **CONFIG** button steps through the five display menus. When one of these menus is shown you can push **ENTER** to access that function. The **CLEAR** button will return the unit to its normal operating mode and cause the display to show the channel level bar graph. The **CLEAR** button DOES NOT clear entered values. The arrow buttons are used to set menu selections.

**SYSTEM MODE**

The RA-122 currently uses only the **NORMAL** setting for system mode.

At the RA-122 front panel - push **CONFIG** until the System Setup appears on the status display.

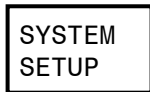

Push **ENTER**. The System Mode menu will be shown.

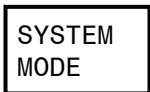

Push **ENTER**. The System Mode Selection menu will be shown.

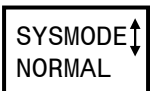

Use the **↑** and **↓** buttons to select the **NORMAL** mode. Push **ENTER** when finished.

**SYSTEM POWER SETUP**

**CAUTION**  
TURN OFF ALL CHANNELS AND OPEN ALL CHANNEL CIRCUIT BREAKERS BEFORE CHANGING THE INPUT POWER SETUP.

In addition to making the correct power connections for the power source at your installation, the RA-122 must be set up to correctly respond to the power type.

At the RA-122 front panel - push **CONFIG** until the System Setup menu appears on the Status display.

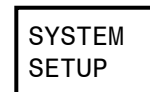

Push **ENTER**. Then push **CONFIG** until the System Power menu appears on the status display.

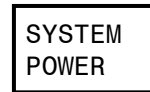

Push **ENTER**. The display will show the current power configuration. For example:

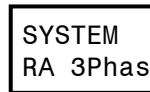

Use the **↑** and **↓** buttons to select a configuration corresponding to the actual power being supplied to the RA-122. Push **ENTER** when correct power type is shown. The available choices are shown below.

- RA 3Phas    120/208V 3 Phase Power Source
- RA 2Phas    120/240V Single Phase Power Source
- OR
- 2 Phases of 120/208V 3 Phase Source

**NOTE: There are several other settings available in this menu. These other choices do not apply to the RA-122 dimmer**

**UNIT ADDRESS ASSIGNMENT**

When using a single RA-122 unit in a system, the unit address **MUST BE SET TO 00**. One (and only one) RA-122 in a multiple unit system must be set to unit address 00. Other units should be assigned in a consecutive order.

## RA – 122 RACK MOUNT ARCHITECTURAL DIMMER

Revision 0.93

OWNERS MANUAL

09/26/2011

At the RA-122 front panel - push **CONFIG** until the System Setup appears on the status display.

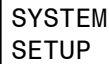

Push **ENTER**. Then push **CONFIG**. The System ID Set menu will be shown.

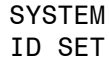

Push **ENTER**. The display shows the unit address.

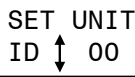

Set the desired address by pushing the  $\uparrow$  and  $\downarrow$  buttons.

Push **ENTER**. Then push **CLEAR** to return to the normal operating mode.

### DIMMER CHANNEL SETUP

Individual channels within the RA-122 dimmer can be set for different behaviors. Any channel may be limited to a user selected maximum intensity level. Limiting applies to manual, scene, and DMX operation. Any channel may also be set to run as NON-DIM (or RELAY).

### CHANNEL LIMITING

At the RA-122 front panel - push **CONFIG** until the Dimmer Setup menu appears on the display.



Push **ENTER**. The channel limit menu will be shown.

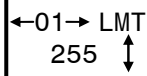

Use the  $\rightarrow$  and  $\leftarrow$  buttons to select a channel. Then use the  $\downarrow$  and  $\uparrow$  buttons to set its limiting value. Push **ENTER** when finished. The limit range on the menu is between 10 and 255 which corresponds to lighting intensity of between 4 and 100 percent.

### CHANNEL NON-DIM (RELAY) MODE

To set a channel to Non-Dim: Push **CONFIG** until the Dimmer Setup menu appears on the display.



Push **ENTER**. Then push **CONFIG**. The display will show the menu:

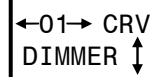

Use the  $\rightarrow$  and  $\leftarrow$  buttons to select a channel. Then use the  $\downarrow$  and  $\uparrow$  buttons to switch between DIMMER and NON-DIM. Push **ENTER** when finished.

### DMX I/O SETUP

DMX I/O Setup consists of two functions. Dimmer channel assignment and Remote lockout.

### DIMMER CHANNEL ASSIGNMENT

Dimmer channel assignment is used to assign individual RA-122 channels (circuits) to a DMX control channel. Each dimmer channel (1 - 12) is fully patchable to any of 512 DMX control channels.

At the RA-122 front panel - push **CONFIG** until the DMX I/O Setup menu appears on the display.

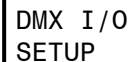

Push **ENTER**. The display shows RA-122 dimmer channels on the top line. The currently assigned DMX channel is shown on the lower line prefixed by "DMX".

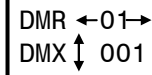

Use the  $\rightarrow$  and  $\leftarrow$  buttons to select a dimmer channel.

Then use the  $\downarrow$  and  $\uparrow$  buttons to assign it to a DMX channel. Push **ENTER** after each channel assignment. Push **CLEAR** to exit from the menu. It will not clear your settings.

**RA – 122 RACK MOUNT ARCHITECTURAL DIMMER**

Revision 0.93

**OWNERS MANUAL**

09/26/2011

**CONSOLE LOCKOUT:** You can set any dimmer channel output to ignore DMX signal inputs from a DMX console by assigning it to DMX channel 000. This feature can be used with house lights or other special lighting. The channel will still respond to wall remotes but the DMX console will be ignored.

**REMOTE LOCKOUT**

The Remote Lockout function prevents the RA-122 from responding to the smart remote wall stations when a DMX signal from a control console is present. Simple remote stations will still function.

At the RA-122 front panel - push **CONFIG** until the DMX I/O Setup menu appears on the display.

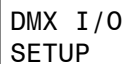

DMX I/O  
SETUP

Push **ENTER**. Then push **CONFIG**. The display will show the lockout menu.

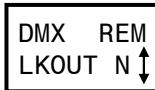

DMX REM  
LKOUT N

Use the ↓ and ↑ buttons to select Y (yes) or N (no). Push **ENTER** when the desired state is shown.

**CREATING AND EDITING SCENES**

At the RA-122 front panel - push **CONFIG** until the SCENE SETUP menu appears on the display.



SCENE  
SETUP

Push **ENTER**. The display shows the current scene number.

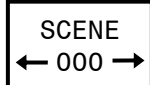

SCENE  
← 000 →

Use the ← and → buttons to select the scene you want to set up and push **ENTER**. Scene 00 controls blackout fade time. Scene 01 is the first actual scene.

There are three ways to create or set up a scene:

1. Set each channel intensity manually (**EDIT SCENE**).

2. Copy another existing scene (**COPY SCENE**). You can then edit the results.
3. Record a snapshot of the current channel intensities (**RECORD LIVE NOW**).

Push **CONFIG** to select the menu for one of the 3 methods described above. The display will show the corresponding menu.

**TO CREATE A SCENE MANUALLY**

Push **ENTER** when **EDIT SCENE** is shown.

The current channel number is shown on the display upper left. The current scene number (which was selected in the previous step) is shown on the display upper right. The settings for three channels are shown on the lower display row.

The **LEFT** channel on the display is the Current Channel (the channel which you will set the intensity level for).

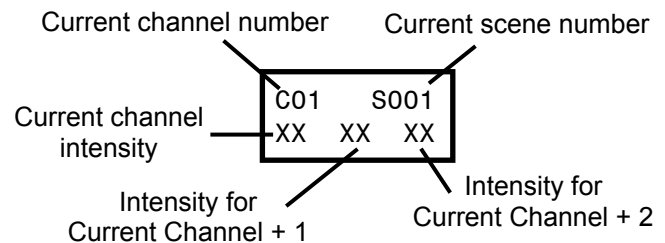

Use the ↓ and ↑ buttons to set the channel output intensity. The display shows the intensity setting as a number between 0% and 100%. A 100% setting is indicated by "FL". A "XX" setting means that the channel will be ignored for the current scene.

Push **ENTER** after the channel level is set.

Use the ← and → buttons to proceed to the next channel to be set up. The lower row of the display will shift to the left. Repeat the channel intensity selection for that channel.

Push **CLEAR** when all the channels for the selected scene are set. This will not clear your scene settings.

To setup another scene - repeat the process above using a different scene selection.

**RA – 122 RACK MOUNT ARCHITECTURAL DIMMER**

Revision 0.93

**OWNERS MANUAL**

09/26/2011

**TO COPY A SCENE**

Push **ENTER** when COPY SCENE is shown. The display will show a menu so you can select an existing scene to copy from.

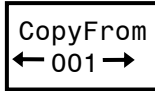

Use the → and ← buttons to select a scene. Then push **ENTER**. The scene will be copied and you will be transferred to the EDIT SCENE menu where you can further adjust the scene if desired.

**TO RECORD A LIVE SCENE**

A scene may be created by recording the current channel intensity levels.

Push **ENTER** when RECORD LIVE NOW is shown.

The existing channel intensities will be copied to the scene. You will be transferred to the EDIT SCENE menu where you can adjust the scene if desired.

**SCENE FADE TIME**

A fade time may be set individually for each scene. This is the time elapsed between a scene fully active and the next scene fully active. The factory default fade time is 3 seconds.

Fade time may be set between .5 and 99.5 seconds and is set from the SCENE SETUP menu (usually as you set channel intensities for the scene).

1. To set a scene fade time - Access the **EDIT SCENE** menu for the desired scene.
2. Use the → and ← buttons to move BEYOND the last channel (CHANNEL 16) for the scene. The display will indicate the current fade time for the scene.
3. Use the ↓ and ↑ buttons to set the desired fade time. Then push **ENTER**.
4. Push **CLEAR** to select another scene for fade time set up.

**SCENE BLACKOUT FADE TIME**

Fade time for the remote stations blackout function is set as an independent function.

The procedure is similar to that for other scenes except the blackout fade time is accessed by selecting SCENE 00 from the SCENE SETUP menu. Factory default fade time is 3 seconds. Blackout fade time may be set between 0.5 and 99.5 seconds. To select a fade time - use the ↓ and ↑ buttons. Push **ENTER** when the desired time is shown.

**OPERATION****OVER TEMPERATURE CONDITION**

The RA-122 has a temperature sensing element which will shut down all operating channels if the temperature rises above 175 deg F. A message "OVERTEMP SHUTDOWN" will be shown on the front panel display in this case. This shutdown cannot be reset except by allowing the unit to cool down.

**COOLING FAN**

The RA-122 is cooled by a fan which is controlled by the dimmers internal circuitry. It will begin running when the unit is powered up. After a short initialization period the fan will run if any dimmer channels are at a non zero intensity and will time out and turn off after aprox. 15 minutes of a "all channels off" condition.

**MANUAL OPERATION**

Individual dimmer channels may be operated from the RA-122 front panel. This is useful during testing and setup operations. Use the → and ← buttons to select a channel. The associated channel on the bar graph display will begin flashing. Use the ↓ and ↑ buttons to raise/lower the lighting intensity for the selected channel.

Manual operation combines with DMX and remote stations settings but does not lock them out.

The **CLEAR** button will turn off all channels when operating manually.

**DMX CONSOLE OPERATION**

If a DMX signal is present when the RA-122 is turned on it will automatically respond to it. A "D" will be shown in the lower right corner of the LCD display if a valid DMX signal is present. Channel intensity levels will be shown on the bar graph display.

**RA – 122 RACK MOUNT ARCHITECTURAL DIMMER**

Revision 0.93

**OWNERS MANUAL**

09/26/2011

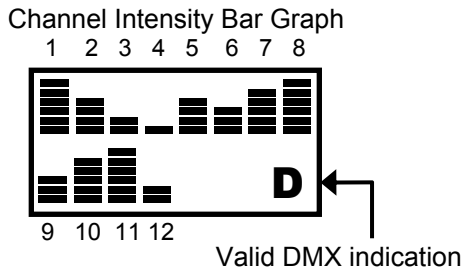
**SMART REMOTES OPERATION**

The RA-122 can store 100 preset scenes which may be activated by smart remotes. See the section "Creating and Editing Scenes" for info about programming the scenes. These scenes are grouped according to which type of smart remote can access them. Scenes 1 - 48 are reserved for push button and IR remotes. Scenes 51 - 86 are used with fader remotes. If multiple RA-122 units are connected to a smart remote then each RA-122 will activate its own corresponding scene.

Both push button and fader remotes may be connected on the same smart remote bus.

**BUTTON AND IR SMART REMOTES OPERATION**

These remotes activate individual scenes within a block of scenes which have been stored in the RA-122 on an "exclusive" basis. In other words only one scene may be on at a time. Currently available remotes are the AC-1009, AC-2016 and AI-1001.

You can select which block of scenes will be activated by the remote. This is done by DIP switches on the back of the remote. For instance, an AC-1009 can be set to control scenes 1 - 8, scenes 9-16, or other blocks of 8 consecutive scenes. There are a total of 6 scene blocks available covering scenes 1 thru 48.

The scene activation buttons will toggle. In other words a scene will go OFF if you push its button while the scene is active.

The OFF button invokes a BLACKOUT for all scenes associated with that remotes scene block. Refer to the smart remote owner manual for specific info on scene addressing. Multiple remotes of this type may be but are not required to be set to the same block of scenes.

**FADER SMART REMOTES OPERATION**

These remotes activate specific individual scenes which have been stored in the RA-122 on a "pile on" basis. In other words multiple scenes will merge together in a "greatest of" fashion. This means that the intensity of any given channel will go to the highest level of all the scenes which use it. Currently available fader remotes are the AF-2004, AF-3007 and AF-5013.

Fader remotes are scene block addressable so you can select which scenes it activate. There are 3 scene blocks available. Each block includes 16 scenes. The first block starts at scene 51. This refers to the lowest numbered fader on the remote. The other faders on that remote will use the next consecutively numbered scenes (52, 53, 54, etc.). The 2nd and 3rd scene blocks begin at scene 67 and 83 respectively.

Multiple remotes of this type may be but are not required to be set to the same block of scenes. Refer to the smart remote owner manual for specific info on setting scene block addressing.

**SIMPLE REMOTES OPERATION**

Scenes 1 - 7 (stored in the RA-122) may be accessed by simple remotes. A BLACKOUT FUNCTION may also be accessed. A simple remote is any switch which provides a momentary contact closure that can be applied to a specific pin on the RA-122 Control Signals Connector (DB25 connector). Lightronics currently offers a APP01 simple remote. This is a "center off, single pole, double throw, momentary toggle switch". It can be used as an entrance switch to activate a scene when someone enters an area.

Alternative devices such as relays, timers, and motion sensors can be used with RA-122s as simple remotes. They are available from various manufacturers.

Operation of a simple remote is dependent upon the device used. In the case of the Lightronics APP01 it is a simple matter of pushing the switch.

**RA – 122 RACK MOUNT ARCHITECTURAL DIMMER**

Revision 0.93

**OWNERS MANUAL**

09/26/2011

**EVENT SYSTEM OPERATION**

The RA-122 includes an internal clock and timer sub system. This subsystem may be used to create events which activate and switch between preset lighting scenes based upon times, days, and dates. A total of 128 events may be programmed.

The clock operates without AC power for approx. 2 weeks and does not require a battery. Event settings are retained in non volatile memory therefore they will not be lost if the RA-122 powered off.

An event is used to trigger any one of 100 scenes which have been previously created and stored in the RA-122. Any scene may be used by multiple events. A scene may be set to turn ON, or OFF, or be ignored by an event.

An event may be set to trigger based on a date of the year and a time. This enables scene activation for one time or infrequent occurrences such as holidays.

An event may also be set to trigger on a daily or multiple times per day basis. Additionally specific days of a week can be designated to be used or skipped. This is a more common type of operation where events are triggered on a regular schedule.

**EVENT SYSTEM ENABLE**

Events programmed in the RA-122 will not trigger unless the event system is set to ON. If the event system is OFF you can still set the clock and program event times and dates but they will never be triggered.

Turning events OFF is used to prevent inadvertent triggers which may have been forgotten about, incorrectly set, or otherwise unaccounted for.

**TO CONTROL EVENT TRIGGERING**

Push **ENTER** from the Event Setup menu. The display will show the event system ON/OFF menu.

```
EVENT
SYS OFF↕
```

Use the **↑** and **↓** button to select ON or OFF. Push **ENTER** when the desired ON/OFF state is shown.

**SETTING THE INTERNAL CLOCK**

The clock must be set to the correct date, time and day of the week in order to operate correctly. This is performed from the RA-122 Event Set Clock menu

At the RA-122 front panel - push **CONFIG** until the Event Setup menu appears on the display.

```
EVENT
SETUP
```

Push **ENTER**. Then push **CONFIG**. The Event Set Clock menu will be shown.

```
EVENT
SETCLOCK
```

Push **ENTER**. The Set Date menu will be shown.

```
SET DATE
00/00/00
```

**SETTING THE DATE**

Use the **←** and **→** buttons to select either the month, day, or year and then use the **↑** and **↓** buttons to set the value. Push **ENTER** after setting each value. Push **CONFIG** to proceed to the Set Time menu.

**SETTING THE TIME OF DAY**

```
SET TIME
00:00
```

Use the **←** and **→** buttons to select either hours or minutes and then use the **↑** and **↓** buttons to set the value. Push **ENTER** after setting each value. Push **CONFIG** to proceed to the Set Day menu.

```
SET DAY
MONDAY
```

**SETTING THE DAY OF THE WEEK**

The day of the week **MUST BE SET** when setting or changing the date. It does not automatically synchronize to the date setting. Once the day is correctly set it will continue to track the date.

Use the **↑** and **↓** buttons to select the day so that it corresponds correctly to the previously set date. Push **ENTER** when the correct day is shown.

A complete layout diagram of the menus for setting the clock is shown below.

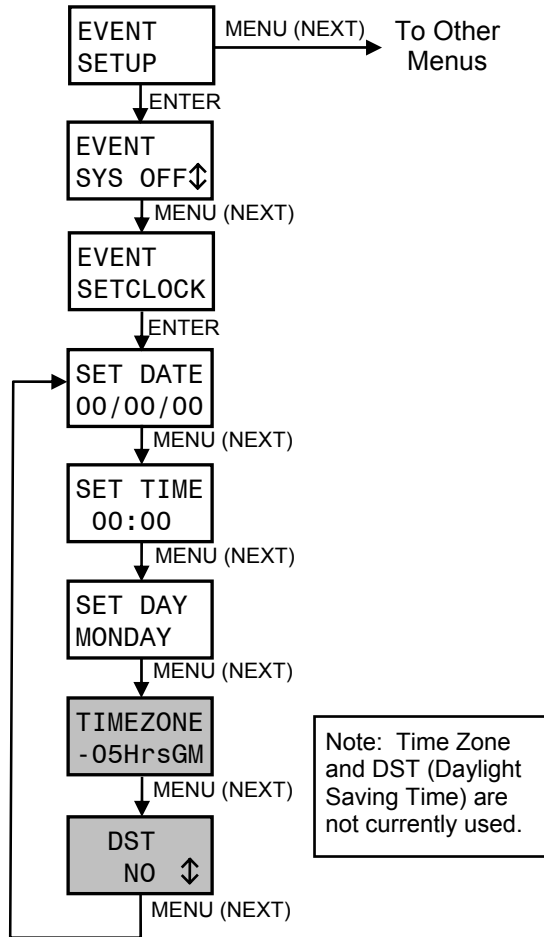

**PROGRAMMING EVENTS**

Events are programmed using the RA-122 Event Editor menus.

Programming an event consists of four steps:

1. Select the event you want to set up (1 - 128).
2. Assign a scene (1 - 100) to the event.
3. Select what action is to be performed for that scene (Turn it ON, Turn it OFF, or IGNORE IT).
4. Assign the DATE/ TIME or DAY(S) / TIME for the event to be triggered.

The complete event editor menus layout is shown below.

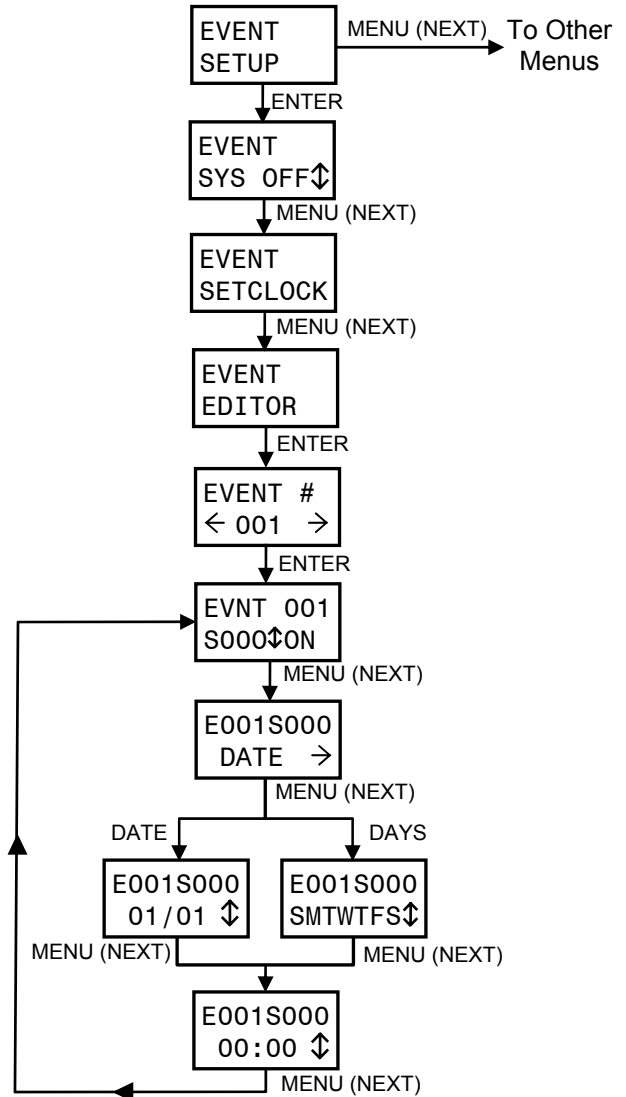

**RA – 122 RACK MOUNT ARCHITECTURAL DIMMER**

Revision 0.93

**OWNERS MANUAL**

09/26/2011

**SELECTING AN EVENT**

From the **EVENT EDITOR** menu - Push **ENTER**. The display will show the event selection menu as follows.

```
EVENT #
< 001 >
```

If an event already has a scene assigned to it then the event number will be followed by an asterisk (\*).

Use the **←** and **→** buttons to select the event number. Then push **ENTER** to proceed to the scene number and scene action menu. If you push and hold down the **←** or **→** button - the event number will skip to the next programmed event and stop.

**ASSIGNING A SCENE AND SCENE ACTION**

The top row of this menu shows the number of the event you are working on. The bottom row shows the assigned scene and the action to perform.

```
EVNT 001
S000↓ON
```

Use the **←** and **→** buttons to select either the scene number or action. Your selection is indicated by flashing that part of the menu. Use the **↑** and **↓** buttons to change the value. Scenes 0 - 100 may be assigned. Available actions are ON, OFF, and XXX (IGNORE). Push **ENTER** once a value has been selected. A setting of XXX disables the event even if a scene for it has been set.

Push **CONFIG** to proceed to the next menu or push **CLEAR** to revert to the event number selection menu.

**CHOOSING DATE OR DAY BASED EVENTS**

This menu enables selection of either DATE based or DAY based operation. The menu will show either:

```
E001S000
DATE →
```

OR

```
E001S000
DAYS →
```

The top row shows the event number and scene number you are working on.

Use the **←** and **→** buttons to switch between DATE and DAYS. Push **CONFIG** to proceed to the next menu for setting the date or day and the time of day. Push **CLEAR** to revert to the event number selection menu.

**SETTING DATE BASED TRIGGERS**

The top row of these menus show the event and scene number you are working on.

The bottom row is used to set the trigger date and the time of day.

To set the date:

```
E001S000
01/01 ↓
```

Use the **←** and **→** buttons to select either the month or day of the month. Your selection is indicated by flashing that part of the menu. The date format is MM/DD (month on the left). Use the **↑** and **↓** buttons to change the value. Push **ENTER** once a value has been selected.

**CAUTION:** If you set an invalid date (such as February 30th) there will be no warning and the event will NEVER trigger.

Push **CONFIG** to proceed with setting the trigger time or push **CLEAR** to revert to the event number selection menu.

To set the trigger time:

```
E001S000
00:00 ↓
```

Use the **←** and **→** buttons to select hours or minutes. Your selection is indicated by flashing that part of the menu. The format for hours is 0 - 24 (NOT AM/PM). Use the **↑** and **↓** buttons to change the value. Push **ENTER** once a value has been selected.

Push **CONFIG** to revert to the SCENE NUMBER and SCENE ACTION menu or push **CLEAR** to revert to the event number selection menu.

**SETTING DAY BASED TRIGGERS**

The top row of these menus show the event number and scene number you are working on. The bottom row is used to set the trigger days and the time of day.

To set days of the week:

```
E001S000
SMTWTF↓
```

The bottom menu row shows the days. If a day shows as a solid block (■) instead of a character then the event will be skipped (will not trigger on that day).

Use the **←** and **→** buttons to select a week day. Then use the **↑** and **↓** buttons to change between trigger and skip. Push **ENTER** once a value has been selected.



**RA – 122 RACK MOUNT ARCHITECTURAL DIMMER**

Revision 0.93

**OWNERS MANUAL**

09/26/2011

Push **CONFIG** to proceed with setting the trigger time or push **CLEAR** to revert to the event number selection menu.

To set the trigger time:

E001S000
00:00 ↕

Use the ← and → buttons to select hours or minutes. Your selection is indicated by flashing that part of the menu. The format for hours is 0 - 23 (not AM/PM).

Use the ↓ and ↑ buttons to change the value. Push **ENTER** once a value has been selected.

Push **CONFIG** to revert to the **SCENE NUMBER** and **SCENE ACTION** menu or push **CLEAR** to revert to the event number selection menu.

**RA – 122 RACK MOUNT ARCHITECTURAL DIMMER**

Revision 0.93

**OWNERS MANUAL**

09/26/2011

**MAINTENANCE AND REPAIR****WARNING****TROUBLESHOOTING**

- To simplify troubleshooting - reset the unit or provide a known simple set of conditions.
- Check that the console is powered and that console channels are correctly patched or set.
- Check the control cable between the dimmer(s) and console.
- Verify the loads and their connections.

**OWNER MAINTENANCE**

**FRONT PANEL FUSES:** The RA-122 has two fuses. The left fuse is 1 Amp. The right fuse is 1/4 Amp. Both are 250V, 1.25 x .25 inch, fast acting fuses. These fuses provide protection for the internal electronic control circuitry and the fan. They may be replaced **ONLY** by fuses of identical type and size.

There are no user serviceable parts inside the unit.

The best way to prolong the life of your unit is to keep it cool, clean, and dry. It is important that the cooling intake and exit vent holes are clean and unobstructed.

Service by other than Lightronics authorized agents may void your warranty.

**OPERATING AND MAINTENANCE ASSISTANCE**

If service is required, contact the dealer from whom you purchased the equipment or contact Lightronics, Service Department, 509 Central Drive, Virginia Beach, VA 23454 TEL 757 486 3588.

Lightronics recommends that you record the serial number of your unit for future reference.

**SERIAL NUMBER** \_\_\_\_\_

**RA-122 UNIT SPECIFICATIONS**

CHANNELS/CAPACITY:	12 @ 2400 Watts each
POWER REQUIREMENTS:	120/208VAC three phase, 80 Amps each line OR 120/240VAC single phase, 120 Amps each line
POWER DEVICES:	Dual 65 Amp SCRs
POWER CONNECTOR:	Terminal strip
CHANNEL OUTPUT:	Edison Plug External Terminal Strip Patch Panel Socapex
CIRCUIT BREAKERS:	20 Amp fast acting
MINIMUM LOAD:	15 Watts
CURVE:	Modified square law
FILTER RISE TIME:	600 usec. minimum
OUTPUT FUNCTION:	DIMMER or RELAY selectable
CONTROL INPUT:	DMX-512 U.S.I.T.T. standard
FRONT PANEL:	8 char. x 2 line LCD display
REMOTE NETWORK:	RS-485, 62.5 Kbaud, bidirectional 9 bit network
LOCAL PRESETS:	100 scenes standard, expandable to 255 scenes
CLOSURE INPUT:	8 inputs for single, dual button, or combine stations
REMOTE STATIONS:	Total of 32 remote stations with unique system addresses
SLAVE UNITS:	Up to 31 additional units may be added
SIZE :	3.5"H x 19"W x 16"D
WEIGHT:	40 pounds



LIGHTRONICS INC. **WARRANTY** LIGHTRONICS INC.

All Lightronics products are warranted for a period of TWO/FIVE YEARS from the date of purchase against defects in materials and workmanship.

---

This warranty is subject to the following restrictions and conditions:

- A) If service is required, you may be asked to provide proof of purchase from an authorized Lightronics dealer.
- B) The FIVE YEAR WARRANTY is only valid if the warranty card is returned to Lightronics accompanied with a copy of the original receipt of purchase within 30 DAYS of the purchase date, if not then the TWO YEAR WARRANTY applies. Warranty is valid only for the original purchaser of the unit.
- C) This warranty does not apply to damage resulting from abuse, misuse, accidents, shipping, and repairs or modifications by anyone other than an authorized Lightronics service representative.
- D) This warranty is void if the serial number is removed, altered or defaced.
- E) This warranty does not cover loss or damage, direct or indirect arising from the use or inability to use this product.
- F) Lightronics reserves the right to make any changes, modifications, or updates as deemed appropriate by Lightronics to products returned for service. Such changes may be made without prior notification to the user and without incurring any responsibility or liability for modifications or changes to equipment previously supplied. Lightronics is not responsible for supplying new equipment in accordance with any earlier specifications.
- G) This warranty is the only warranty either expressed, implied, or statutory, upon which the equipment is purchased. No representatives, dealers or any of their agents are authorized to make any warranties, guarantees, or representations other than expressly stated herein.
- H) This warranty does not cover the cost of shipping products to or from Lightronics for service.
- I) Lightronics Inc. reserves the right to make changes as deemed necessary to this warranty without prior notification.

