

**DESCRIPTION**

The SC-810 is designed to be a compact, DMX controller and snapshot playback station. When used as a standalone controller, the SC-810 is capable of independently controlling 512 channels of DMX and has the ability to record 18 scenes. The scene control is broken down to 10 real time fader controls and 8 push buttons with user defined fade times. This device features the ability to set a fixed output value or park DMX channels. In addition, the SC-810 is able to connect to a DMX data chain with another controller or DMX console; when another DMX controller on the circuit is transmitting DMX, the SC-810 will lock out local control and enter a mode that allows it to record any of the 18 available scenes via DMX snapshot.

Available as either a desktop or wall mounted unit, the SC-810 is the ideal device for architectural control of DMX512 lighting systems, it can be used as a backup to a DMX console, great for controlling LED lighting for special events or anywhere that requires quick, easy control of a full universe of DMX.

**INSTALLATION**

**POWER AND DATA**

SC-810 uses an external 12 Volt/ 1 amp, DC power supply, which is included. Installing power to a wall mount will require landing the red wire to the +12VDC and the black wire to the COM terminal on the four pin plug located on the back of the device.

When installing power and DMX connections to the device, make all low voltage connections and check DC output prior to mating the connector with the male pins located on

the rear of the SC-810. Do not make any of the connections LIVE or while any devices on the DMX data chain are transmitting.

DMX is installed in a similar way on the removable 4 pin connector. Fig 1.1 shows the proper wiring of the connector.

Fig. 1.1

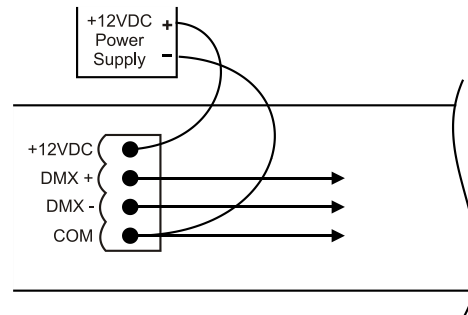

On the SC-810D, a female 5 pin XLR style plug is located beside the power on the rear face of the unit. (Fig 1.2) This can be used as both a DMX input for snapshotting scenes, as well as a DMX output.

A male-to-male 5 pin DMX adapter is required when inputting DMX signal from a console or other output device.

Fig. 1.2

**5 PIN FEMALE XLR CONNECTOR  
FACE VIEW**



## DESK TOP INSTALLATION

The SC-810D (or desk top model) is built into a desk top chassis designed to sit on a desk, podium or shelf.

Install in a dry place away from excessive dust, heat or moisture.

## DMX DATA NETWORK

For the best results, it is advised that - when installed on a large DMX data network or any network containing devices with "Master/Slave" functions such as select Lightronics FXLD or FXLE fixtures - an optically isolated splitter be installed on the output side of the SC-810 in the DMX Data chain.

Desk top units used with an external DMX controller should have the controller's output connected to the output of the SC-810. The DMX line should then be daisy chained to a splitter or the first DMX controlled device in the data chain.

## WALL INSTALLATION

The SC-810W (or wall mount) is designed to fit in a standard 5 gang "new work" style junction box. Be certain to keep line voltage and earth ground connections away from SC-810W and the junction box housing the unit.

## OPERATION

Upon start up, the SC-810 will flash the software version number then go to an OFF state, illuminating the "OFF" LED. To verify that the unit has control of the system and is operating properly, press the OFF/CLR button. Once pressed, the SC-810's OFF/CLR red LED should turn off. Press CHN/MOD and follow all steps in the next two sections of this manual to set outputs. If the SC-810 is actively receiving a DMX signal, the OFF/CLR LED will blink slowly.

### CHN/MOD BUTTON AND LED

The SC-810's CHN/MOD button is used to toggle between scene and channel mode. After startup, the device will default to scene mode. When in this mode, the unit acts as a replay device, each of the buttons and faders will recall any previously recorded scenes.

When the CHN/MOD button is pressed, the amber LED beside the button will illuminate, signifying that the SC-810 is now in channel mode. In this mode, the device can be

used like a DMX console or scene setter, allowing the user to set, change/modify/store scenes on any combination of levels using up to 512 DMX channels.

## SETTING CHANNEL LEVELS

The ten faders on the SC-810 user interface are used to set levels for a block of ten DMX channels at a time. Once set, those levels remain live until they are changed, a clear command is given, or the device senses DMX from another DMX console in line. The SC-810 uses a unique addressing system to access blocks of faders.

DMX channels 1 - 10 are the defaults for fader operation when the unit is powered up and switched to channel mode. To access a block of ten channels other than the default (1-10) the SC-810 uses additive addressing. Utilizing the eight buttons on the left side of the unit, labeled '+10', '+20', '+30', '+50' etc. Addressing is achieved by pushing a combination adding up to the desired DMX start address. Any block of ten channels out of the 512 available channels are accessible using this procedure buttons.

For example, to access channel 256 when starting with the default '+0', press '+50', '+200'. 256 will then be on fader 6. To access channel 250, again starting from the default, press +200, +30, and +10. Channel 250 will now be the 10<sup>th</sup> fader (channel 241 will be the first fader.)

A chart outlining the buttons used to access any of the 512 available DMX channels is available on page 5. (Fig 5.1)

## OFF/CLR BUTTON AND LED

A temporary break in transmission (blackout) can be achieved by pushing the OFF/CLR button. When pushed, the unit will transmit a value of 0 DMX for all channels and the red LED located next to the button will be ON steadily, indicating that an OFF state is active. If pushed a 2nd time, the OFF (blackout) will be released and the unit will resume transmitting its previous DMX levels.

## OPERATION WITH ANOTHER CONTROLLER

The SC-810 can be connected to a DMX chain with another DMX controller/console. When another controller is transmitting on a DMX data chain containing a SC-810, the SC-810 will automatically stop transmitting and begin receiving DMX. When the SC-810 is receiving DMX from another device, the OFF/CLR LED will blink slowly.

The SC-810 defaults to transmit 'last look' (last known values for all channels) for seamless integration with a DMX control console. To use this mode the SC-810 cannot have OFF/CLR pressed when turning on a connected DMX

console. When the SC-810, in a transmit state detects a DMX signal and reverts to receive mode after the DMX console is turned off, the SC810 will take control by transmitting the last look set on both the DMX control console and SC-810.

When a connected controller stops transmitting DMX, the SC-810 will take control. If a scene was active on the SC-810 when before receiving a DMX input the SC810 will restore to that scene. If a scene was not active the SC-810 will transmit the last levels transmitted by the connected console

Push the OFF/CLR button once to enable local operation. The unit will begin sending the DMX values set by using the faders. Values set in channel mode previous to the SC-810 receiving a DMX signal will not be retained.

### REC SWITCH AND REC LED

The RECORD button is a pushbutton recessed below the face plate to prevent accidental operation of the record function. It is located to the right and below the red RECORD LED. You will need a small tool (such as a piece of solid wire or paperclip) to push the button when recording.

The SC-810 can store scenes created using the SC-810's DMX control feature or snapshot scenes from a connected DMX Device. To record scenes from the SC-810 internally, use the steps outlined in the **SETTING CHANNEL LEVELS** section of this manual to set up the desired look, then follow the steps in this section.

When the SC-810 receives a valid DMX512 signal, the RED LED beside the OFF/CLR button will blink as outlined in the **OPERATION WITH ANOTHER CONTROLLER** section of this manual. Once the LED begins to blink slowly, the SC-810 is ready to start recording scene snapshots. To record or re-record a scene:

1. Set any DMX channels to the value you desire to capture using the SC-810 or control console connected to the SC-810.
2. Hold down REC on the SC-810 until its LED indicator begins to flash (about 3 sec.).
3. Push the button or move the fader in the location corresponding to the scene you want recorded. The REC and scene LEDs may flash, indicating that recording was completed successfully.
4. Repeat steps 1 through 3 to record any subsequent scenes.

[www.lightronics.com](http://www.lightronics.com)

To clear a scene, turn the CLR/OFF button on, hold record, than select the scene.

### RECALLING SCENES

When recording scenes to the SC-810, it is important to keep in mind that scenes recorded on the buttons will be played

back at the levels recorded with the set fade rate, while scenes recorded to faders can be manually faded in and out or played back at a fraction of the original percentages captured.

Set CHN/MOD to off, (LED not illuminated) then press, push or pull up any previously recorded button or fader. When multiple scenes are recalled the SC-810 will combine the recorded values with the highest value taking precedence. For example, when channels 11-20 are recorded to button 1 at 80% and button 2 at 90%, if both buttons are pushed the SC-810 will transmit a value of 90% on channels 11-20. A combination of buttons and faders can be used to recall several scenes at a time. This technique can be used as a means of controlling fixtures with several attributes or parameters. For example, if a group of LED fixtures controlled by a SC-810 have a 4 channel profile that contains a discrete channel for each; MASTER, RED, GREEN and BLUE, by assigning the master channels at full for each fixture to one push button, a control group can be created. Each fixture's respective RED, GREEN, and BLUE channel can then be assigned to a common fader, allowing for seamless control of the colors without crossfading the master intensities.

### FAD BUTTON AND LED

The FAD (Fade) button is used to assign a fade time to one of the 8 push button presets.

A fade can be set to only the 8 push button scenes, the ten faders are programmed to always operate in real time. Fades can be set between 0-55 seconds in increments of 1 full second. The fade time is established using a similar additive method to the addressing system covered earlier. When setting fade times to the scenes any other operation taking place on the device will be frozen until the process is complete.

To record or change a fade time use the following steps.

1. Press the FAD button until the scene indicator lights begin to flash while the FAD LED indicators flash in unison and the FAD indicator light will illuminate.

2. Press the scene button you wish to add a fade time to.
3. Set the fader # (1-10) representing the time in second you desire to assign to the scene at full and pull any other faders down to 0. For any time over 10 seconds, press the button corresponding to the amount of time you wish to add. Buttons with + values represent the additional amount of time in seconds.(ex to add 10 seconds press +10 button.)
4. Press the REC button until the red REC led begins to flash (approx. 3-5 seconds.)
5. Then press the FAD button to confirm and return to normal operation (Faders set to full representing the fade time programed will come on at full once the fade time has been saved.)
6. Repeat steps 1-5 to set additional fade times.

If at any point a mistake is made or you wish to exit fade time programming, push the FAD button and the unit will return to normal operation.

### SETTING FIXED DMX CHANNELS (PARKING)

DMX channels can be assigned a fixed output level or be “parked” at any value above 1%. When a channel is assigned a fixed DMX output value the output will remain at that value in both scene and channel mode and cannot be overridden by scene recalls or by independent DMX control. To set a DMX channel to a FIXED output:

1. Set the fader(s) associated with the DMX channel to the level(s) desired.
2. Press the FAD button for 3-5 seconds or until the FAD indicator LED begins to flash.
3. Press the REC button for 3-5 seconds or until the FAD and REC LED indicators both begin to flash.
4. Press FAD button to record the change.

The output of a fixed Channel can be momentarily interrupted using the OFF command. To erase a fixed channel output follow the steps above setting the level for each of the DMX channels to regain normal operation to a value of 0% on the fader.

It is important to note which channels have been parked so that they can be changed later if needed.

### MAINTENANCE AND REPAIR

### TROUBLESHOOTING

No LEDs lit when plugged in.

-Verify that SC-810's 12v power supply is plugged in to a working outlet and that the LED on the power supply is lit.

-Verify DMX and power connections as well as their polarity.

- Push the OFF/CLR button, when pushed the red LED next to it should illuminate.

Scene activated does not appear to be what was stored.

-Verify all DMX connections are made securely.

- Confirm the DMX polarity for each connection is correct.

-Check that the scene has not been recorded over by re-creating the scene on the SC-810 or DMX console and re-recording.

Some dimmers or fixtures are not responding to the SC-810.

- Make sure that the dimmer/fixtures addresses are set to the proper DMX channels.

-Make sure that the DMX daisy chain is wired properly and terminated.

### CLEANING

The best way to prolong the life of your SC-810 is to keep it dry, cool, and clean.

***COMPLETELY DISCONNECT THE UNIT BEFORE CLEANING AND MAKE SURE IT IS COMPLETELY DRY BEFORE RECONNECTING***

The unit exterior may be cleaned using a soft cloth dampened with a mild detergent/water mixture or a mild spray-on type cleaner. **DO NOT SPRAY ANY LIQUID** directly on the unit. **DO NOT IMMERSE** the unit in any liquid or allow liquid to get into the fader or push button controls. **DO NOT USE** any solvent based or abrasive cleaners on the unit.

### REPAIRS

There are no user serviceable parts in the SC-810. Service by anyone other than Lightronics authorized agents will void your warranty.

### OPERATING AND TECHNICAL ASSISTANCE

Your local dealer and Lightronics factory personnel can help you with operation or maintenance problems. Please read the applicable parts of this manual before calling for assistance.

SC-810 DMX CONTROLLER  
**OWNERS MANUAL**

Version 1.5

05/11/18

If service is required - contact the dealer from whom you purchased the unit or contact Lightronics directly.

Lightronics, Service Dept., 509 Central Drive, Virginia Beach, VA 23454 TEL: (757) 486-3588.

Fig 5.1

DMX Ch.	Address Buttons		DMX Ch.	Address Buttons
1-10	+0(Default)		261-270	+200,+50,+10
11-20	+10		271-280	+200,+50,+20
21-30	+20		281-290	+200,+50,+30
31-40	+30		291-300	+200,+50,+30,+10
41-50	+10,+30		301-310	+300
51-60	+50		311-320	+300,+10
61-70	+50,+10		321-330	+300,+20
71-80	+50,+20		331-340	+300,+30
81-90	+50,+30		341-350	+300,+10,+30
91-100	+50,+30,+10		351-360	+300,+50
101-110	+100		361-370	+300,+50,+10
111-120	+100,+10		371-380	+300,+50,+20
121-130	+100,+20		381-390	+300,+50,+30
131-140	+100,+30		391-400	+300,+50,+30,+10
141-150	+100,+10,+30		401-410	+300,+100
151-160	+100,+50		411-420	+300,+100,+10
161-170	+100,+50,+10		421-430	+300,+100,+20
171-180	+100,+50,+20		431-440	+300,+100,+30
181-190	+100,+50,+30		441-450	+300,+100,+10,+30
191-200	+100,+50,+30,+10		451-460	+300,+100,+50
201-210	+200		461-470	+300,+100,+50,+10
211-220	+200,+10		471-480	+300,+100,+50,+20
221-230	+200,+20		481-490	+300,+100,+50,+30
231-240	+200,+30		491-500	+300,+100,+50,+30,+10
241-250	+200,+10,+30		501-510	+300,+200
251-260	+200,+50		511-512	+300,+200,+10



All Lightronics products are warranted for a period of TWO/FIVE YEARS from the date of purchase against defects in materials and workmanship.

---

This warranty is subject to the following restrictions and conditions:

- A) If service is required, you may be asked to provide proof of purchase from an authorized Lightronics dealer.
- B) The FIVE YEAR WARRANTY is only valid if the warranty card is returned to Lightronics accompanied with a copy of the original receipt of purchase within 30 DAYS of the purchase date, if not then the TWO YEAR WARRANTY applies. Warranty is valid only for the original purchaser of the unit.
- C) This warranty does not apply to damage resulting from abuse, misuse, accidents, shipping, and repairs or modifications by anyone other than an authorized Lightronics service representative.
- D) This warranty is void if the serial number is removed, altered or defaced.
- E) This warranty does not cover loss or damage, direct or indirect arising from the use or inability to use this product.
- F) Lightronics reserves the right to make any changes, modifications, or updates as deemed appropriate by Lightronics to products returned for service. Such changes may be made without prior notification to the user and without incurring any responsibility or liability for modifications or changes to equipment previously supplied. Lightronics is not responsible for supplying new equipment in accordance with any earlier specifications.
- G) This warranty is the only warranty either expressed, implied, or statutory, upon which the equipment is purchased. No representatives, dealers or any of their agents are authorized to make any warranties, guarantees, or representations other than expressly stated herein.
- H) This warranty does not cover the cost of shipping products to or from Lightronics for service.
- I) Lightronics Inc. reserves the right to make changes as deemed necessary to this warranty without prior notification.