

SR516D/SR516W

ARCHITECTURAL CONTROLLER

Version: 1.01

Date: 04/08/2022

TABLE OF CONTENTS

DESCRIPTION	3
POWER REQUIREMENTS	3
SR516D INSTALLATION	3
CONNECTIONS	3
POWER CONNECTIONS	3
DMX CONNECTIONS	3
REMOTE CONNECTIONS	3
PUSHBUTTON SMART REMOTES CONNECTIONS	4
SIMPLE SWITCH REMOTE STATIONS	4
SR516W INSTALLATION	4
CONNECTIONS	4
POWER CONNECTIONS	4
DMX CONNECTIONS	5
REMOTE CONNECTIONS	5
PUSHBUTTON SMART REMOTES CONNECTIONS	5
SIMPLE SWITCH REMOTE STATIONS	5
SR516 CONFIGURATION SETUP	6
RECORD BUTTON	6
ACCESSING AND SETTING FUNCTIONS	6
SETTING FADE TIMES	6
SIMPLE REMOTE SWITCH BEHAVIOR	7
SETTING SIMPLE SWITCH INPUT OPTIONS	7
SETTING SYSTEM CONFIGURATION OPTIONS 1	7
SETTING SYSTEM CONFIGURATION OPTIONS 2	7
CONTROLLING EXCLUSIVE SCENE ACTIVATION	8
SETTING SCENES TO BE PART OF A MUTUALLY EXCLUSIVE GROUP	8
FACTORY RESET	8
TO PERFORM A FACTORY RESET	8
OPERATION	8
DMX INDICATOR LIGHT	8
SCENE BANKS	8
TO RECORD A SCENE	9
SCENE ACTIVATION	9
TO ACTIVATE A SCENE	9
THE OFF BUTTON	9
RECALL LAST SCENE	9
MAINTENANCE AND REPAIR	9
TROUBLESHOOTING	9
OWNER MAINTENANCE	9
CLEANING	9
REPAIRS	10
OPERATING AND MAINTENANCE ASSISTANCE	10
WARRANTY	10
SR516 PROGRAMMING DIAGRAM	11

DESCRIPTION

The SR516 provides simplified remote control for DMX512 lighting systems. The unit can store up to 16 complete lighting scenes and activate them with the push of a button. Scenes are organized in two banks of eight scenes each. Scenes in the SR516 can operate in either an “exclusive” mode (one scene active at a time) or in a “pile-on” mode which enables multiple scenes to be added together.

The unit can operate with other types of Lightronics smart remotes and simple remote switches for control at multiple locations. These remotes are wall mount units and connect to the SR516 via low voltage wiring and can turn SR516 scenes on and off.

This unit can also be used for lighting system operation without the use of a trained operator at the main lighting controller. The SR516 retains stored scenes when powered off. It can be used continuously without a DMX lighting controller. The controller is needed only to record scenes from.

POWER REQUIREMENTS

The SR516 is powered from an external low voltage power supply which provides +12 Volts DC, 2 Amps minimum. This is included with the SR516.

SR516D INSTALLATION

The SR516D is portable and is intended to be used on a desktop or other suitable horizontal surface. A 120 Volt AC power outlet is needed for the power supply.

CONNECTIONS

TURN OFF ALL CONSOLES, DIMMER PACKS AND POWER SOURCES BEFORE MAKING EXTERNAL CONNECTIONS TO THE SR516D.

The SR516D is provided with connectors on the rear edge of the unit for connection from a DMX controller to DMX devices, remote stations, and power. Tables and diagrams for connections are included in this manual.

POWER CONNECTION

The external power connector on the rear of the unit is a 2.1mm plug. The center pin is the positive (+) side of the connector.

DMX CONNECTIONS

A five pin MALE XLR connector is used to connect a DMX lighting controller (needed to create scenes).

A five pin FEMALE XLR connector is used to connect to a DMX splitter or chain of DMX devices.

DMX signals should be carried by a twisted pair, shielded, low capacitance (25pF/ft. or less) cable.

DMX signal identification is shown in the table below. It applies to both the MALE and FEMALE connectors. Pin numbers are visible on the connector.

Connector Pin #	Signal Name
1	DMX Common
2	DMX DATA -
3	DMX DATA +
4	Not Used
5	Not Used

REMOTE CONNECTIONS

The SR516D can operate with two types of remote wall stations. The first type is Lightronics pushbutton smart remote stations. These remotes include the Lightronics line of AC, AK, and AI remote stations. The other type is simple momentary switch closures. Both remote types connect to the SR516D via a 9 pin (DB9) connector on the rear edge of the unit. The DB9 connector pin assignments are shown in the table below. Pin numbers are visible on the connector face.

Connector Pin #	Signal Name
1	Simple Switch Common
2	Simple Switch #1
3	Simple Switch #2
4	Simple Switch #3
5	Simple Switch Common
6	Smart Remote Common
7	Smart Remote DATA -
8	Smart Remote DATA +
9	Smart Remote Voltage +

Refer to the wall remote owner’s manuals for specific wiring instructions for connections at the remote.

PUSHBUTTON SMART REMOTE CONNECTIONS

Communication with these stations is over a 4 wire daisy chain bus which consists of a dual twisted pair data cable(s). One pair carries the data (Smart Remote DATA - and Smart Remote DATA +). These connect to pin 7 & 8 of the DB9 connector. The other pair supplies power to the stations (Smart Remote Common and Smart Remote Voltage +). These connect to pin 6 & 9 of the DB9 connector.

Multiple pushbutton smart remotes of mixed type can be connected on this bus.

An example using two Lightronics AC1109 smart remote wall stations is shown below.

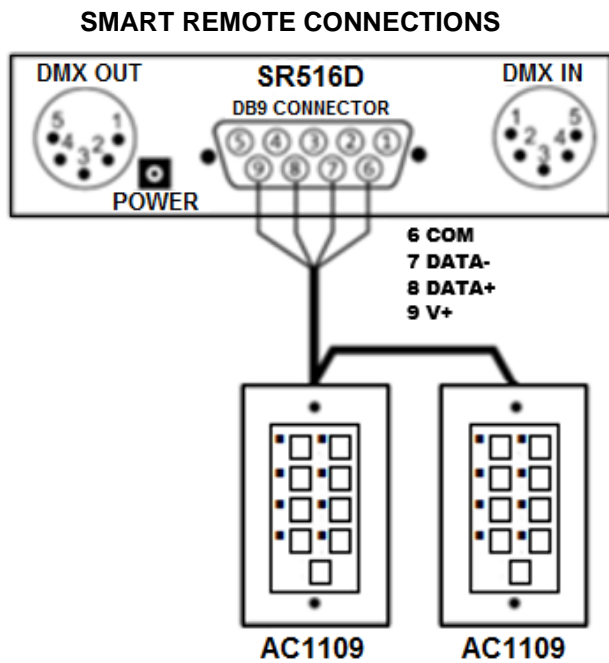

SIMPLE SWITCH REMOTE STATIONS

The first five pins of the SR516D DB9 connector are used to connect simple switch remote signals. They are COM, SWITCH 1, SWITCH 2, SWITCH 3, COM. The two SIMPLE COM terminals are connected to each other internally.

The following diagram shows an example using two switch remotes. Several other user designed schemes could be used to wire these remotes.

The example uses a Lightronics APP01 switch station and a typical momentary pushbutton switch.

SIMPLE SWITCH REMOTE EXAMPLE

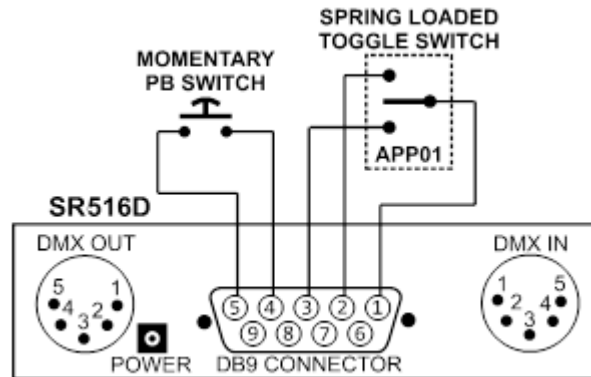

If the SR516D simple switch functions are set to factory default operation the switches will operate as follows for the connection example shown above.

1. Scene #1 will be turned ON when the toggle switch is pushed up.
2. Scene #1 will be turned OFF when the toggle switch is pushed down.
3. Scene #2 will be turned ON or OFF each time the momentary pushbutton switch is pushed.

SR516W INSTALLATION

The SR516W installs in a standard double gang wall switch box. A screwless trim plate is supplied.

CONNECTIONS

TURN OFF ALL CONSOLES, DIMMER PACKS AND POWER SOURCES BEFORE MAKING EXTERNAL CONNECTIONS TO THE SR516W.

The SR516W is provided with plug-in screw terminal connectors on the rear of the unit. Connection terminals are marked as to their function or signal. A connection diagram is included in this manual. The connectors can be removed by carefully pulling them away from the circuit board.

POWER CONNECTIONS

A two pin connector is provided for power. The connector terminals are marked on the circuit card to indicate the required polarity. Correct polarity **MUST BE OBSERVED AND MAINTAINED.**

EXTERNAL CONNECTIONS

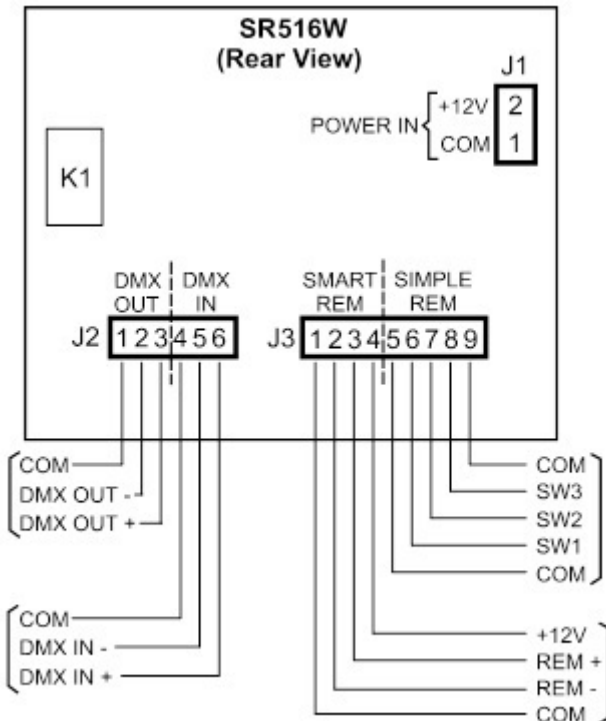

DMX CONNECTIONS

Three terminals are used to connect a DMX lighting console (needed to create scenes). They are marked as COM, DMX IN -, and DMX IN +.

The DMX signal should be transmitted over a twisted pair, shielded, low capacitance cable.

REMOTES CONNECTIONS

The SR516 can operate with two types of remote stations. The first type is Lightronics pushbutton smart remote stations. The other is simple momentary switch closures.

PUSHBUTTON SMART REMOTES CONNECTIONS

These remotes include the Lightronics line of AC, AK, and AI remote stations. Communication with these stations is over a 4 wire daisy chain bus which consists of dual twisted pair, shielded low capacitance data cable(s). One pair carries the data. The other pair supplies power to the remote stations. Multiple smart remotes of mixed type can be connected on this bus.

Bus connections for the smart remotes are on the terminals marked COM, REM-, REM+, and +12V.

Refer to the wall remote owner’s manuals for specific wiring instructions for connections at the remote.

SMART REMOTE CONNECTIONS EXAMPLE

An example using two Lightronics AC1109 smart remote wall stations is shown below.

SMART REMOTE CONNECTIONS

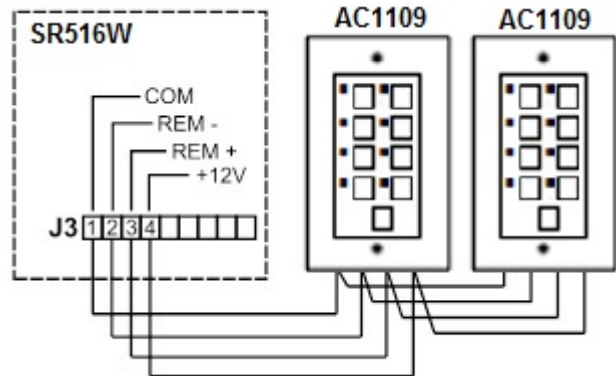

SIMPLE SWITCH REMOTE STATIONS

Five terminals are used to connect simple switch remote signals. They are marked as COM, SWITCH 1, SWITCH 2, SWITCH 3, COM. The simple remote COM terminals are connected to each other on the printed circuit board.

An example with two switch remotes is shown below.

SIMPLE SWITCH REMOTE CONNECTIONS

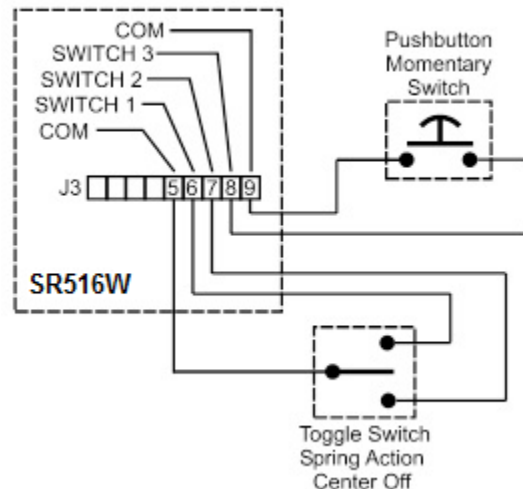

The example uses a Lightronics APP01 switch station and a momentary pushbutton switch. If the SR516W simple switch pushbutton are set to factory default operation the switches will operate as follows.

1. Scene #1 will be turned ON when the toggle switch is pushed up.
2. Scene #1 will be turned OFF when the toggle switch is pushed in the down.
3. Scene #2 will be toggled on or off each time the momentary pushbutton switch is pushed.

SR516 CONFIGURATION SETUP

The behavior of the SR516 is controlled by a set of function codes and their associated values. A full list of these codes and a brief description is shown below. Specific instructions for each function are provided in this manual.

- | | |
|----|---|
| 11 | Bank A, Scene 1 Fade Time |
| 12 | Bank A, Scene 2 Fade Time |
| 13 | Bank A, Scene 3 Fade Time |
| 14 | Bank A, Scene 4 Fade Time |
| 15 | Bank A, Scene 5 Fade Time |
| 16 | Bank A, Scene 6 Fade Time |
| 17 | Bank A, Scene 7 Fade Time |
| 18 | Bank A, Scene 8 Fade Time |
| 21 | Bank B, Scene 1 Fade Time |
| 22 | Bank B, Scene 2 Fade Time |
| 23 | Bank B, Scene 3 Fade Time |
| 24 | Bank B, Scene 4 Fade Time |
| 25 | Bank B, Scene 5 Fade Time |
| 26 | Bank B, Scene 6 Fade Time |
| 27 | Bank B, Scene 7 Fade Time |
| 28 | Bank B, Scene 8 Fade Time |
| 31 | Blackout (OFF) Fade Time |
| 32 | ALL Scenes and Blackout Fade Time |
| 33 | Simple Switch Input #1 Options |
| 34 | Simple Switch Input #2 Options |
| 35 | Simple Switch Input #3 Options |
| 36 | Not Used |
| 37 | System Configuration Options 1 |
| 38 | System Configuration Options 2 |
| 41 | Mutually Exclusive Group #1 Scenes |
| 42 | Mutually Exclusive Group #2 Scenes |
| 43 | Mutually Exclusive Group #3 Scenes |
| 44 | Mutually Exclusive Group #4 Scenes |
| 88 | Factory Reset - Invokes a default configuration |

A diagram at the back of this manual gives a quick guide to programming the unit.

RECORD BUTTON

This is a very small recessed pushbutton in a small hole in the faceplate. It is just below the RECORD LED (labeled REC). You will need a small rod (such

as a ball point pen or paper clip) to push it.

ACCESSING AND SETTING FUNCTIONS

1. Hold down REC for more than 3 seconds. The REC light will begin blinking.
2. Push RECALL. The RECALL and REC lights will blink alternately.
3. Enter a 2 digit function code using the scene buttons (1 - 8). The scene lights will flash a repeating pattern of the code entered. The unit will return to its normal operating mode after about 60 seconds if no code is entered.
4. Push RECALL. The RECALL and REC lights will be ON. The scene lights (in some cases including the OFF (0) and BANK (9) lights) will show the current function setting or value.

Your action now depends on which function was entered. Refer to the instructions for that function. You can enter new values and push REC to save them or push RECALL to exit without changing the values.

SETTING FADE TIMES (Function Codes 11 - 32)

The fade time is the minutes or seconds to move between scenes or for scenes to go ON or OFF. The fade time for each scene can be individually set. The allowable range is from 0 seconds to 99 minutes.

Fade time is entered as 4 digits and can be either minutes or seconds.

Numbers entered from 0000 - 0099 will be recorded as seconds.

Numbers 0100 and larger will be recorded as even minutes and the last two digits will not be used. In other words, seconds will be ignored.

After accessing a function (11 - 32) as described in ACCESSING AND SETTING FUNCTIONS:

1. The scene lights + OFF (0) and BANK (9) lights will be flashing a repeating pattern of the current fade time setting.
2. Use the scene buttons to enter a new fade time (4 digits). Use OFF for 0 and BANK for 9 if needed.
3. Push REC to save the new function setting.

Function Code 32 is a master fade time function which will set ALL fade times to the value entered. You can use this for a base setting for fade times and then set individual scenes to other times as needed.

SIMPLE REMOTE SWITCH BEHAVIOR

The SR516 is very versatile in how it can respond to the simple remote switch inputs. Each switch input can be set to operate according to its own settings.

Most settings pertain to momentary switch closures. The MAINTAIN setting allows the use of a regular ON/OFF switch. When used this way, the applicable scene(s) will be ON while the switch is closed and OFF when the switch is open.

Other scenes can still be activated and the OFF button will turn the MAINTAIN scene OFF.

SETTING SIMPLE SWITCH INPUT OPTIONS

(Function Codes 33 - 35)

After accessing a function as described in ACCESSING AND SETTING FUNCTIONS:

1. The scene lights including OFF (0) and BANK (9) will flash a repeating pattern of the current setting.
2. Use the scene buttons to enter a value (4 digits). Use OFF for 0 and BANK A/B for 9 if needed.
3. Push REC to save the new function value.

The function values and description are as follows:

SCENE ON/OFF CONTROL

0101 - 0116 Turn ON Scene (1-16)
0201 - 0216 Turn OFF Scene (1-16)
0301 - 0316 Toggle ON/OFF Scene (1-16)
0401 - 0416 MAINTAIN Scene (1-16)

OTHER SCENE CONTROLS

0001 Ignore this switch input
0002 Blackout - turn off all scenes
0003 Recall last scene(s)

SETTING SYSTEM CONFIGURATION OPTIONS 1

(Function Code 37)

The system configuration options are specific behaviors which can be turned ON or OFF.

After accessing a function code (37) as described in ACCESSING AND SETTING FUNCTIONS:

1. The scene lights (1 - 8) will show which options are on. An ON light means the option is active.
2. Use the scene buttons to toggle the associated option ON and OFF.
3. Push REC to save the new function setting.

The configuration options are as follows:

SCENE 1 SCENE RECORD LOCKOUT
Disables scene recording. Applies to ALL scenes.

SCENE 2 DISABLE BANK BUTTON
Disables the Bank button. All scenes are still available from smart remotes if they are set to use them.

SCENE 3 SMART REMOTE LOCKOUT VIA DMX
Disables the Smart Remotes if a DMX input signal is present.

SCENE 4 LOCAL BUTTON LOCKOUT VIA DMX
Disables the SR516 scene buttons if a DMX input signal is present.

SCENE 5 SIMPLE REMOTE LOCKOUT VIA DMX
Disables the simple remote switches if a DMX input signal is present.

SCENE 6 TURN ON LAST SCENE AT POWERUP
If a scene was active when the SR516 was powered off then it will turn on that scene when power is restored.

SCENE 7 EXCLUSIVE GROUP TOGGLE DISABLE
Disables the ability to turn off all the scenes in an exclusive group. It forces the last live scenes in the group to stay on unless you push OFF.

SCENE 8 DISABLE FADE INDICATION
Prevents the scene lights from blinking during scene fade time.

SETTING SYSTEM CONFIGURATION OPTIONS 2

(Function Code 38)

SCENE 1-5 SAVED FOR FUTURE EXPANSION

SCENE 6 MASTER/SLAVE MODE
Changes the SR516 from transmit mode to receive mode when a master dimmer (ID 00), SC or SR unit is already in the system.

SCENE 7 CONTINUOUS DMX TRANSMISSION
SR516 will continue to send DMX string at 0 values with no DMX input or no scenes active rather than no DMX signal output

SCENE 8 DMX FAST TRANSMIT
Reduces the DMX interslot time to increase the DMX transmission rate.

CONTROLLING EXCLUSIVE SCENE ACTIVATION

During normal operation multiple scenes can be active at the same time. Channel intensities for multiple scenes will combine in a "greatest of" manner.

You can cause a scene or multiple scenes to operate in an exclusive manner by making them part of a mutually exclusive group.

There are four groups which can be set. If scenes are part of a group then only one scene in the group can be active at any given time.

Other scenes (not part of that group) can be on at the same time as scenes in a group.

Unless you are going to set one or two simple groups of non-overlapping scenes you may want to experiment with the settings to get different effects.

SETTING SCENES TO BE PART OF A MUTUALLY EXCLUSIVE GROUP (Function Codes 41 - 44)

After accessing a function (41 - 44) as described in ACCESSING AND SETTING FUNCTIONS:

1. The scene lights will show which scenes are part of the group. Use the BANK A/B button as needed to check both banks.
2. Use the scene buttons to toggle scenes on/off for the group.
3. Push REC to save the new group set.

FACTORY RESET (Function Code 88)

A Factory Reset will invoke the following conditions:

1. All scenes will be erased.
2. All fade times will be set to two seconds.
3. Simple switch functions will be set as follows:
 - Input #1 Turn ON Scene 1
 - Input #2 Turn OFF Scene 1
 - Input #3 Toggle Scene 2 ON and OFF
4. All System Configuration Options (Function

Codes 37 and 38) will be turned OFF.

5. Mutually Exclusive groups will be cleared (no scenes in the groups).

TO PERFORM A FACTORY RESET:

After accessing a function (88) as described in ACCESSING AND SETTING FUNCTIONS:

1. The OFF (0) light will repeat a pattern of 4 flashes.
2. Enter **0516** (the model number of the product).
3. Push REC. The scene lights will flash briefly and the unit will return to its operating mode.

OPERATION

The SR516 turns on automatically when power is applied from the external power supply. There is no ON/OFF switch or button.

When an SR516 is not powered, a DMX signal fed to the DMX IN connector (if connected) is directly routed to the DMX OUT connector.

DMX INDICATOR LIGHT

This indicator conveys the following information about the DMX input and DMX output signals.

- | | |
|-------------|---|
| 1. OFF | DMX is NOT being received.
DMX is NOT being transmitted.
(No scenes are active). |
| 2. BLINKING | DMX is NOT being received.
DMX IS being transmitted.
(One or more scenes are active). |
| 3. ON | DMX is being received.
DMX is being transmitted. |

SCENE BANKS

The SR516 can store 16 operator created scenes and activate them with the push of a button. Scenes are organized in two banks (A and B). A bank switch button and indicator are provided for switching between banks. Bank "B" is active when the BANK A/B light is on.

TO RECORD A SCENE

A DMX control device must be connected and used to create the scene to be stored in the SR516.

Check that Scene Record Lockout is OFF.

1. Create a scene using the control console faders to set dimmer channels to the desired levels.
2. Select the bank where you want to store the scene.
3. Hold down REC on the SR516 until its LED and the scene lights begin to flash (about 2 sec.).
4. Push the button for the scene you want recorded.

The REC and scene lights will go OFF which shows that recording was completed.

The REC and scene lights will stop flashing after about 20 seconds if you do not select a scene.

5. Repeat steps 1 through 4 to record other scenes.

SCENE ACTIVATION

Playback of scenes stored in the SR516 will occur regardless of control console operation or status. This means that scenes activated from the unit will add to or "pile on" to the channel data from a DMX console.

TO ACTIVATE A SCENE

1. Set the SR516 to the desired scene bank.
2. Push the button associated with the desired scene. The scene will fade in according to the fade time function settings.

The scene light will blink until the scene reaches its full level. It will then be ON. The blink action can be disabled by a configuration option.

The scene activation buttons are toggles. To turn off an active scene – push its associated button.

Scene activation can be either "exclusive" (only one scene may be active at a time) or "pile on" (multiple scenes on at the same time) depending on setup function selections. During "pile on" operation - multiple active scenes will combine in a "greatest of" fashion with respect to channel intensity.

THE OFF BUTTON

The OFF button blacks out or turns off all active scenes. Its indicator is on when active.

RECALL LAST SCENE

The RECALL button can be used to reactivate the scene or scenes which were on prior to an OFF condition. The RECALL indicator will light when a recall is in effect. It will not step back through a series of previous scenes.

MAINTENANCE AND REPAIR

TROUBLESHOOTING

1. A valid DMX control signal must be present to record a scene.
2. If a scene does not activate correctly – it may have been overwritten without your knowledge.
3. If you cannot record scenes – check that the record lockout option is not on.
4. Check that the DMX cables and/or remote wiring are not defective. A MOST COMMON PROBLEM SOURCE.
5. To simplify troubleshooting - set the unit to known set of conditions. A factory reset can be performed (see page 7).
6. Make sure the fixture or dimmer addresses are set to the desired channels.
7. Check that the controller softpatch (if applicable) is set correctly.

OWNER MAINTENANCE

CLEANING

The best way to prolong the life of your SR516 is to keep it dry, cool, and clean.

COMPLETELY DISCONNECT THE UNIT BEFORE CLEANING AND MAKE SURE IT IS COMPLETELY DRY BEFORE RECONNECTING.

The unit exterior may be cleaned using a soft cloth dampened with a mild detergent/water mixture or a mild spray-on type cleaner. DO NOT SPRAY ANY AEROSOL OR LIQUID directly on the unit. DO NOT IMMERSER the unit in any liquid or allow liquid to get into the controls. DO NOT USE any solvent based or abrasive cleaners on the unit.

REPAIRS

There are no user serviceable parts in the unit. Service by other than Lightronics authorized agents will void your warranty.

OPERATING AND MAINTENANCE ASSISTANCE

Dealer and Lightronics factory personnel can help you with operation or maintenance problems. Please read the applicable parts of this manual before calling for assistance.

If service is required - contact the dealer from whom you purchased the unit or contact Lightronics, Service Dept., 509 Central Drive, Virginia Beach, VA 23454 TEL: (757) 486-3588.

WARRANTY INFORMATION AND
REGISTRATION - CLICK LINK BELOW

www.lightronics.com/warranty.html

SR516 PROGRAMMING DIAGRAM

