

SR - 516

DMX REMOTE STATION

Version: 1.10

Date: 05/16/2013

**TABLE OF CONTENTS**

<b>DESCRIPTION</b>	<b>3</b>
<b>POWER REQUIREMENTS</b>	<b>3</b>
<b>INSTALLATION</b>	<b>3</b>
CONNECTIONS	3
POWER CONNECTIONS	3
DMX CONNECTIONS	3
REMOTES CONNECTIONS	3
PUSHBUTTON SMART REMOTES CONNECTIONS	3
CONNECTIONS AT REMOTE UNITS	4
SMART REMOTE CONNECTIONS EXAMPLE	4
SIMPLE SWITCH REMOTE STATIONS	4
<b>SR-516 CONFIGURATION SETUP</b>	<b>4</b>
RECORD BUTTON	5
ACCESSING AND SETTING FUNCTIONS	5
SETTING FADE TIMES	5
SIMPLE REMOTE SWITCH BEHAVIOR	5
SETTING SIMPLE SWITCH INPUT OPTIONS	5
SETTING SYSTEM CONFIGURATION OPTIONS 1	5
SETTING SYSTEM CONFIGURATION OPTIONS 2	6
CONTROLLING EXCLUSIVE SCENE ACTIVATION	6
SETTING SCENES TO BE PART OF A MUTUALLY EXCLUSIVE GROUP	6
FACTORY RESET	6
TO PERFORM A FACTORY RESET	7
<b>OPERATION</b>	<b>7</b>
DMX LIGHT	7
SCENE BANKS	7
TO RECORD A SCENE	7
SCENE ACTIVATION	7
TO ACTIVATE A SCENE	7
THE OFF BUTTON	7
<b>MAINTENANCE AND REPAIR</b>	<b>8</b>
TROUBLESHOOTING	8
OWNER MAINTENANCE	8
CLEANING	8
REPAIRS	8
OPERATING AND MAINTENANCE ASSISTANCE	8
<b>PROGRAMMING DIAGRAM</b>	<b>9</b>
<b>WARRANTY</b>	<b>10</b>

**DESCRIPTION**

The SR-516 provides wall station remote control to DMX-512 lighting systems. The unit can store up to 16 scenes and activate them with the push of a button. Scenes are organized in two banks of eight scenes each. Scenes in the SR-516 can operate in either an “exclusive” mode (one scene active at a time) or in a “pile-on” mode which enables multiple scenes to be added together.

The unit can operate with other types of Lightronics smart remotes and simple remote switches. These remotes connect to the SR-516 via low voltage wiring and can turn SR-516 scenes on and off.

This unit can also be used for lighting system operation without the use of a trained operator at the main lighting console. The SR-516 retains stored scenes when powered off. It can be used continuously without a control console. The console is needed only to record scenes.

**POWER REQUIREMENTS**

The SR-516 is powered from an external low voltage power supply which provides +12 Volts DC at 800 mA. A UL Listed power supply is provided.

**INSTALLATION**

The SR-516 installs in a standard double gang wall switch box. A double screwless trim plate is supplied.

**CONNECTIONS**

**TURN OFF ALL CONSOLES, DIMMER PACKS, AND POWER SOURCES BEFORE MAKING EXTERNAL CONNECTIONS TO THE SR-516**

The SR-516 is provided with plug-in screw terminal connectors on the rear of the unit. Connection terminals are marked as to their function or signal. A connection diagram is included in this manual. The connectors can be removed by carefully pulling them away from the circuit board.

**POWER CONNECTIONS**

A two pin connector is provided for power. The connector terminals are marked on the circuit card to indicate the required polarity. Correct polarity **MUST BE OBSERVED AND MAINTAINED.**

**EXTERNAL CONNECTIONS**

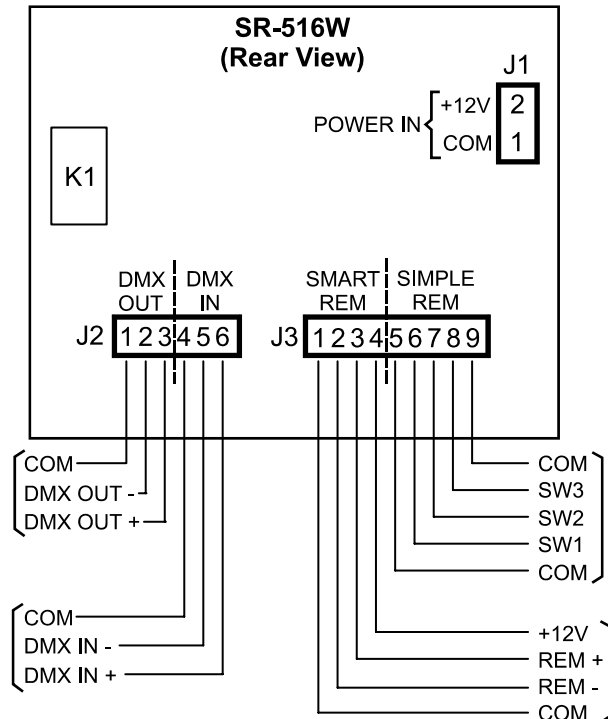

**DMX CONNECTIONS**

Three terminals are used to connect a DMX lighting console (needed to create scenes). They are marked as COM, DMX IN -, and DMX IN +.

The DMX signal should be transmitted over a twisted pair, shielded, low capacitance cable.

**REMOTES CONNECTIONS**

The SR-516 can operate with two types of remote stations. The first type is Lightronics pushbutton smart remote stations. The other is simple momentary switch closures.

**PUSHBUTTON SMART REMOTES CONNECTIONS**

These remotes include the Lightronics AC-1109, AC-2116, and IR remote AI-1001. Communication with these stations is over a 4 wire daisy chain bus which consists of dual twisted pair, shielded low capacitance data cable(s). One pair carries the data. The other pair supplies power to the remote stations. Multiple smart remotes of mixed type can be connected on this bus.

Bus connections for the smart remotes are on the terminals marked COM, REM-, REM+, and +12V

**CONNECTIONS AT REMOTE UNITS**

Refer to the wall remote owners manual for specific wiring instructions for connections at the remote.

**SMART REMOTE CONNECTIONS EXAMPLE**

An example using two Lightronics AC-1109 smart remote wall stations is shown below.

**SMART REMOTE CONNECTIONS**

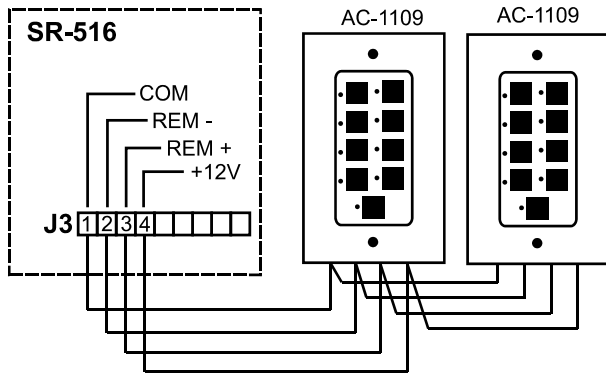

**SIMPLE SWITCH REMOTE STATIONS**

Five terminals are used to connect simple switch remote signals. They are marked as COM, SWITCH 1, SWITCH 2, SWITCH 3, COM. The COM terminals are connected to each other on the printed circuit board.

An example with two switch remotes is shown below.

**SIMPLE SWITCH REMOTE CONNECTIONS**

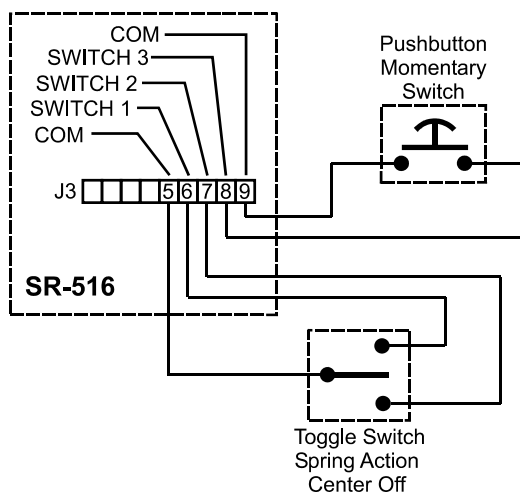

The example uses a Lightronics APP01 switch station and a momentary pushbutton switch. If the SR-516 simple switch functions are set to factory default operation then the switches will operate as follows.

1. Scene #1 will be turned ON when the toggle switch is pushed up.
2. Scene #1 will be turned OFF when the toggle switch is pushed in the down.
3. Scene #2 will be toggled on or off each time the momentary pushbutton switch is pushed.

**SR-516 CONFIGURATION SETUP**

SR-516 behavior is controlled by a set of function codes and their associated values. A list of these codes and a brief description is shown below. Specific instructions for each function are provided in this manual.

- 11 Bank 1 Scene 1 Fade Time
- 12 Bank 1 Scene 2 Fade Time
- 13 Bank 1 Scene 3 Fade Time
- 14 Bank 1 Scene 4 Fade Time
- 15 Bank 1 Scene 5 Fade Time
- 16 Bank 1 Scene 6 Fade Time
- 17 Bank 1 Scene 7 Fade Time
- 18 Bank 1 Scene 8 Fade Time
- 21 Bank 2 Scene 1 Fade Time
- 22 Bank 2 Scene 2 Fade Time
- 23 Bank 2 Scene 3 Fade Time
- 24 Bank 2 Scene 4 Fade Time
- 25 Bank 2 Scene 5 Fade Time
- 26 Bank 2 Scene 6 Fade Time
- 27 Bank 2 Scene 7 Fade Time
- 28 Bank 2 Scene 8 Fade Time
- 31 Blackout (OFF) Fade Time
- 32 ALL Scenes and Blackout Fade Time
- 33 Simple Switch Input #1 Options
- 34 Simple Switch Input #2 Options
- 35 Simple Switch Input #3 Options
- 36 Not Used
- 37 System Configuration Options 1
- 38 System Configuration Options 2 - Not Used
- 41 Mutually Exclusive group 1 scene selection
- 42 Mutually Exclusive group 2 scene selection
- 43 Mutually Exclusive group 3 scene selection
- 44 Mutually Exclusive group 4 scene selection
- 88 Factory Reset - Invokes a default configuration

A diagram at the back of this manual gives a quick guide to programming the unit.

**RECORD BUTTON**

This is a small pushbutton recessed in a small hole in the faceplate just below the RECORD LED (labeled REC). You will need a small rod (such as a ball point pen) to activate it.

**ACCESSING AND SETTING FUNCTIONS**

1. Hold down REC for more than 2 seconds. The REC light will begin blinking.
2. Push RECALL. The RECALL and REC lights will blink alternately.
3. Enter a 2 digit function code using the scene buttons (1 - 8). The scene lights will flash a repeating pattern of the code entered. The unit will return to its normal operating mode after about 60 seconds if no code is entered.
4. Push RECALL. The RECALL and RECORD lights will be ON. The scene lights (in some cases including the OFF(0) and Bank(9) lights) will show the current setting for the function entered.

Your action now depends on which function was entered. Refer to the instructions for that function. You can enter new values and push REC to save them or push RECALL to exit without changing the values.

**SETTING FADE TIMES (Function Codes 11 - 32)**

The fade time is the minutes or seconds to move between scenes or for scenes to go ON or OFF. The fade time for each scene can be individually set. The allowable range is from 0 seconds to 99 minutes.

Fade time is entered as 4 digits as minutes or seconds. Numbers from 0000 - 0099 are recorded as seconds.

Numbers 0100 and larger will be recorded as even minutes and the last two digits will not be used. In other words seconds will be ignored.

After accessing a function (11 - 32) as described in ACCESSING AND SETTING FUNCTIONS:

1. The scene lights + OFF(0) and BANK(9) lights will be flashing a repeating pattern of the current fade time setting.
2. Use the scene buttons to enter a new fade time (4 digits). Use OFF for 0 and BANK for 9 if needed.

3. Push REC to save the new fade time.

Function Code 32 is a master fade time function which will set ALL fade times to the value entered. You can use this for a base setting for fade times and then set individual scenes to other times as needed.

**SIMPLE REMOTE SWITCH BEHAVIOR**

The SR-516 is very versatile in how it can respond to simple remote switch inputs. Each switch input can be set to operate according its own function settings.

Most settings pertain to momentary switch closures. The MAINTAIN setting allows the use of a regular ON/OFF switch. When used this way - the applicable scene(s) will be ON while the switch is closed and go OFF when the switch opens. Other scenes can still be activated and the off button will turn the MAINTAIN scene OFF.

**SETTING SIMPLE SWITCH INPUT OPTIONS**  
(Function Codes 33 - 35)

After accessing a function (33 - 35) as described in ACCESSING AND SETTING FUNCTIONS:

1. The scene lights including OFF(0) and BANK(9) will be flashing a repeating pattern of the current setting.
2. Use the scene buttons to enter a value (4 digits). Use OFF for 0 and BANK for 9 if needed.
3. Push REC to save the new function value.

The function values and description are as follows:

**SCENE ON/OFF CONTROL**

0101 - 0116 Turn ON Scene (01-16)  
0201 - 0216 Turn OFF Scene (1-16)  
0301 - 0316 Toggle ON/OFF Scene (1-16)  
0401 - 0416 MAINTAIN Scene (1-16)

**OTHER SCENE CONTROLS**

0001 Ignore this switch input  
0002 Blackout - turn off all scenes  
0003 Recall last scene(s)

**SETTING SYSTEM CONFIGURATION OPTIONS 1**  
(Function Code 37)

The system configuration options are specific behaviors which can be turned ON or OFF.

After accessing function code (37) as described in ACCESSING AND SETTING FUNCTIONS:

1. The scene lights (1 - 8) will show which options are on. An ON light means the option is active.
2. Use the scene buttons to toggle the associated option ON and OFF.
3. Push REC to save the new function data.

The configuration options are as follows:

**SCENE 1 SCENE RECORD LOCKOUT**  
Disables scene recording. Applies to ALL scenes.

**SCENE 2 DISABLE BANK BUTTON**  
Disables the Bank button. All scene are still available from smart remotes if they are set to use them.

**SCENE 3 REMOTES LOCKOUT VIA DMX**  
Disables the Smart Remotes if a DMX input a from a console is present.

**SCENE 4 LOCAL BUTTON LOCKOUT VIA DMX**  
Disables ALL the SR-516 buttons if a DMX input from a console is present.

**SCENE 5 SIMPLE REMOTE LOCKOUT VIA DMX**  
Disables the simple remote switches if a DMX input from a console is present.

**SCENE 6 TURN ON LAST SCENE AT POWER UP**  
If a scene was active when the SR-516 was powered off then it will turn on that scene when power is restored.

**SCENE 7 EXCLUSIVE GROUP TOGGLE DISABLE**  
Disables the ability to turn off all the scenes in an exclusive group. It forces the last live scene in the group to stay on unless you push OFF.

**SCENE 8 DISABLE FADE INDICATION**  
Prevents the scene lights from blinking during scene fade time.

#### **SETTING SYSTEM CONFIGURATION OPTIONS 2** (Function Code 38)

These options are not used during normal operation and should always be **OFF**. They are controlled the same as SYSTEM CONFIGURATION OPTIONS 1.

#### **CONTROLLING EXCLUSIVE SCENE ACTIVATION**

During normal operation multiple scenes can be active at the same time. Channel intensities for multiple scenes will combine in a "greatest of " manner.

You can cause a scene or multiple scenes to operate in a exclusive manner by making them part of a mutually exclusive group.

There are four groups which can be set. If scenes are part of a group then only one scene in the group can be active at any given time.

Other scenes (not part of that group) can be on at the same time as scenes in a group.

Unless you are going to set one or two simple groups of non overlapping scenes you may want to experiment with the group settings to achieve different effects.

#### **SETTING SCENES TO BE PART OF A MUTUALLY EXCLUSIVE GROUP** (Function Codes 41 - 44)

After accessing a function (41 - 44) as described in ACCESSING AND SETTING FUNCTIONS:

1. The scene lights will show which scenes are part of the group. Use the BANK A/B button as needed to check both banks.
2. Use the scene buttons to toggle scenes on/off for the group.
3. Push REC to save the new group set.

#### **FACTORY RESET** (Function Code 88)

A Factory Reset will invoke the following conditions:

1. All scenes will be erased.
2. All fade times will be set to two seconds.
3. Simple switch functions will be set as follows:
  - Input #1 Turn ON Scene 1
  - Input #2 Turn OFF Scene 1
  - Input #3 Toggle Scene 2 ON and OFF
4. All System Configuration Options (Function Codes 37 and 38) will be turned OFF.
5. Mutually Exclusive groups will be cleared (no scenes in the groups).

**TO PERFORM A FACTORY RESET:**

After accessing the function (88) as described in ACCESSING AND SETTING FUNCTIONS:

1. The OFF(0) light will repeat a pattern of 4 flashes.
2. Enter **0516** (the model number of the product).
3. Push REC. The scene lights will flash briefly and the unit will return to its operating mode.

**OPERATION**

The SR-516 turns on automatically when power is applied from the external power supply. There is no ON/OFF switch or button.

When the SR-516 is not powered, a DMX signal from a control console (if connected) is directly routed to the dimmers via the DMX OUT connection. In other words the console will be directly connected to the dimmers.

**DMX INDICATOR LED**

This indicator conveys the following information about the DMX input and DMX output signals.

1. OFF DMX is NOT being received.  
DMX is NOT being transmitted to dimmers.  
(No scenes are active).
2. BLINKING DMX is NOT being received.  
DMX IS being transmitted.  
(one or more scenes are active).
3. ON DMX IS being received from a console.  
DMX IS being transmitted to the dimmers.

**SCENE BANKS**

The SR-516 can store 16 operator created scenes and activate them with the push of a button. Scenes are organized in two banks (A and B). A bank switch button and indicator are provided for switching between banks. Bank B is active when the BANK A/B light is on.

**TO RECORD A SCENE**

A DMX console or controller must be connected and used to create the scene to be stored in the SR-516.

Check that Scene Record Lockout is OFF.

1. Create a scene using the control console faders to set dimmer channels to the desired levels.
2. Select the bank you want to store the scene in.
3. Hold down REC on the SR-516 until its LED and the scene LEDs begin to flash (about 2 sec.).
4. Push the button for the scene you want recorded.

The RECORD and scene lights will go OFF which shows that recording was completed.

The RECORD and scene lights will stop flashing after about 20 seconds if you do not select a scene.

5. Repeat steps 1 through 4 to record other scenes.

**SCENE ACTIVATION**

Playback of scenes stored in the SR-516 will occur regardless of control console operation or status. This means that scenes activated from the unit will add to or "pile on" to the channel data from a DMX console.

**TO ACTIVATE A SCENE**

1. Set the SR-516 to the desired scene bank.
2. Push the button associated with the desired scene. The scene will fade in according to the fade time function settings. The scene light will blink until the scene has faded to its full level. It will then be ON. The blinking indication can be disabled by a configuration option

The scene activation buttons are toggles. To turn off an active scene – push its associated button.

Scene activation can be either "exclusive" (only one scene may be active at a time) or "pile on" (multiple scenes on at the same time) depending on setup function selections. During "pile on" operation - multiple active scenes will combine in a "greatest of" fashion with respect to channel intensity.

**THE OFF BUTTON**

The "OFF" button blacks out or turns off all active scenes. Its indicator is on when active.

**RECALL LAST SCENE**

The RECALL button can be used to reactivate the scene or scenes which were active prior to an OFF condition. The RECALL indicator will light when a recall is in effect. It will not step back through a series of previous scenes.

**MAINTENANCE AND REPAIR****TROUBLESHOOTING**

1. A valid DMX console signal must be present to record a scene.
2. If a scene does not activate correctly— it may have been overwritten without your knowledge.
3. If you cannot record scenes – check that the Record Lockout option is not on.
4. Check that the DMX cables and/or remote wiring are not defective. **A MOST COMMON PROBLEM SOURCE.**
5. To simplify troubleshooting - set the unit to known set of conditions. A Factory Reset can be performed
6. Make sure that the dimmer addresses are set to the desired channels.
7. Check that the console softpatch (if applicable) is set correctly.

**OWNER MAINTENANCE****CLEANING**

The best way to prolong the life of your SR-516 is to keep it dry, cool, and clean.

**COMPLETELY DISCONNECT THE UNIT BEFORE CLEANING AND MAKE SURE IT IS COMPLETELY DRY BEFORE RECONNECTING**

The unit exterior may be cleaned using a soft cloth dampened with a mild detergent/water mixture or a mild spray-on type cleaner. **DO NOT SPRAY ANY LIQUID** directly on the unit. **DO NOT IMMERSE** the unit in any liquid or allow liquid to get into the controls. **DO NOT USE** solvent based or abrasive cleaners.

**REPAIRS**

There are no user serviceable parts in the unit. Service by other than Lightronics authorized agents will void your warranty.

**OPERATING AND MAINTENANCE ASSISTANCE**

Dealer and Lightronics Factory personnel can help you with operation or maintenance problems. Please read the applicable parts of this manual before calling for assistance.

If service is required - contact the dealer from whom you purchased the unit or contact Lightronics, Service Dept., 509 Central Drive, Virginia Beach, VA 23454 TEL: (757) 486-3588.



SR-516 PROGRAMMING DIAGRAM

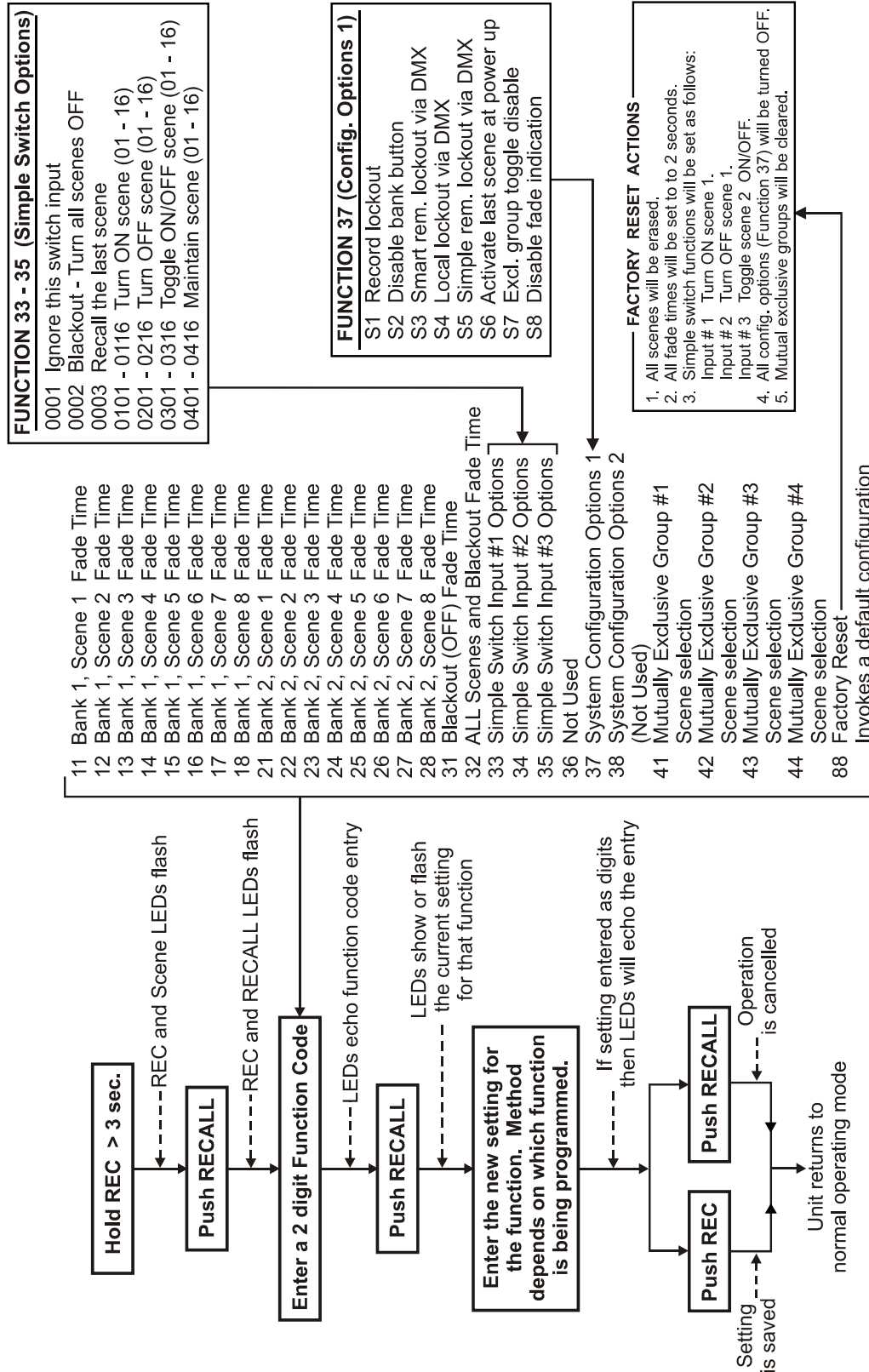



All Lightronics products are warranted for a period of TWO/FIVE YEARS from the date of purchase against defects in materials and workmanship.

---

This warranty is subject to the following restrictions and conditions:

- A) If service is required, you may be asked to provide proof of purchase from an authorized Lightronics dealer.
- B) The FIVE YEAR WARRANTY is only valid if the warranty card is returned to Lightronics accompanied with a copy of the original receipt of purchase within 30 DAYS of the purchase date, if not then the TWO YEAR WARRANTY applies. Warranty is valid only for the original purchaser of the unit.
- C) This warranty does not apply to damage resulting from abuse, misuse, accidents, shipping, and repairs or modifications by anyone other than an authorized Lightronics service representative.
- D) This warranty is void if the serial number is removed, altered or defaced.
- E) This warranty does not cover loss or damage, direct or indirect arising from the use or inability to use this product.
- F) Lightronics reserves the right to make any changes, modifications, or updates as deemed appropriate by Lightronics to products returned for service. Such changes may be made without prior notification to the user and without incurring any responsibility or liability for modifications or changes to equipment previously supplied. Lightronics is not responsible for supplying new equipment in accordance with any earlier specifications.
- G) This warranty is the only warranty either expressed, implied, or statutory, upon which the equipment is purchased. No representatives, dealers or any of their agents are authorized to make any warranties, guarantees, or representations other than expressly stated herein.
- H) This warranty does not cover the cost of shipping products to or from Lightronics for service.
- I) Lightronics Inc. reserves the right to make changes as deemed necessary to this warranty without prior notification.